



DEPARTMENT OF EDUCATION

GRADE 12 PHYSICS

MODULE 3



WAVES



FLEXIBLE OPEN AND DISTANCE EDUCATION
PRIVATE MAIL BAG, P.O. WAIGANI, NCD
FOR DEPARTMENT OF EDUCATION
PAPUA NEW GUINEA

2016

Writers:
Gideon Messa & Vincent Kapui

Editors:
Dr. Mirzi Betasolo
Elizabeth.W.Aimundi



GRADE 12

PHYSICS

MODULE 3

WAVES

IN THIS MODULE, YOU WILL LEARN ABOUT:

- 12.3.1: PROPERTIES OF WAVES**
- 12.3.2: SUPERPOSITION AND INTERFERENCE OF WAVES**
- 12.3.3: WAVES AND BOUNDARIES**
- 12.3.4: APPLICATION**



Acknowledgements

We acknowledge the contribution of all Lower and Upper Secondary Teachers who in one way or another helped to develop this Course.

Special thanks are given to the staff of the Science Department- FODE who played active role in coordinating writing workshops, outsourcing of module writing and editing processes involving selected teachers in NCD.

We also acknowledge the professional guidance and services provided throughout the processes of writing by the members of:

Science Subject Review Committee-FODE
Academic Advisory Committee-FODE
Science Department- CDAD

This book was developed with the invaluable support and co-funding of the GO-PNG and World Bank.

MR. DEMAS TONGOGO
Principal-FODE



Flexible Open and Distance Education
Papua New Guinea

Published in 2016
@ Copyright 2016, Department of Education
Papua New Guinea

All rights reserved. No part of this publication may be reproduced, stored in a retrieval system, or transmitted in any form or by any means electronic, mechanical, photocopying, recording or any other form of reproduction by any process is allowed without the prior permission of the publisher.

Printed by the Flexible, Open and Distance Education
ISBN 978-9980-89-561-5
National Library Services of Papua New Guinea



TABLE OF CONTENTS

	Page
Title.....	1
ISBN and Acknowledgement.....	2
Contents.....	3
Secretary’s Message.....	4
 MODULE 12.3: WAVES	 5 - 75
Course Introduction.....	5
Learning Outcomes.....	6
Time Frame.....	7
 12.3.1: Properties of Waves.....	 8 - 28
<input type="checkbox"/> Types of Waves.....	10 - 18
<input type="checkbox"/> Wave Properties.....	19 - 28
 12.3.2: Superposition and Interference of Waves.....	 28 - 37
<input type="checkbox"/> Superposition and Interference of Waves	28 - 37
 12.3.3: Waves and Boundaries.....	 38 - 60
<input type="checkbox"/> Propagation of Waves at Boundaries.....	39 – 60
 12.3.4: Application.....	 60 - 63
<input type="checkbox"/> Applications Involving Light Waves.....	60 - 65
<input type="checkbox"/> Applications Involving Sound Waves	66 - 72
 Summary.....	 73 - 75
Answers to Learning Activities.....	76 - 82
References.....	83



SECRETARY'S MESSAGE

Achieving a better future by individuals students, their families, communities or the nation as a whole, depends on the curriculum and the way it is delivered.

This course is part and parcel of the new reformed curriculum – the Outcome Base Education (OBE). Its learning outcomes are student centred and written in terms that allow them to be demonstrated, assessed and measured.

It maintains the rationale, goals, aims and principles of the National OBE Curriculum and identifies the knowledge, skills, attitudes and values that students should achieve.

This is a provision of Flexible, Open and Distance Education as an alternative pathway of formal education.

The Course promotes Papua New Guinea values and beliefs which are found in our constitution, Government policies and reports. It is developed in line with the National Education Plan (2005 – 2014) and addresses an increase in the number of school leavers which has been coupled with a limited access to secondary and higher educational institutions.

Flexible, Open and Distance Education is guided by the Department of Education's Mission which is fivefold;

- to facilitate and promote integral development of every individual
- to develop and encourage an education system which satisfies the requirements of Papua New Guinea and its people
- to establish, preserve, and improve standards of education throughout Papua New Guinea
- to make the benefits of such education available as widely as possible to all of the people
- to make education accessible to the physically, mentally and socially handicapped as well as to those who are educationally disadvantaged

The College is enhanced to provide alternative and comparable path ways for students and adults to complete their education, through one system, many path ways and same learning outcomes.

It is our vision that Papua New Guineans harness all appropriate and affordable technologies to pursue this program.

I commend all those teachers, curriculum writers and instructional designers, who have contributed so much in developing this course.



DR. UKE KOMBRA
Secretary

**MODULE 12. 3****WAVES**

Introduction

Waves are everywhere and can be studied in terms of its forms and its method of energy transfer. But firstly, what is a wave? In simple terms, a wave is a disturbance or a vibration that transfers energy from one point to another. The transfer of energy is achieved through a medium or in some cases through vacuum (empty space). The disturbances which transfer the energy in the direction of the wave motion, travels without transferring matter. In other words, matter is not carried with the wave.

Some waves must travel through a substance known as the matter **medium**. It can be solid, liquid or gaseous. Sound, ocean and seismic waves are some waves that travel through a medium. As the wave travel through the medium, the particles of the medium vibrate perpendicular or parallel to the direction of the wave motion. Waves that travel through a medium are called **mechanical waves**.

Not all waves need a medium to travel through. Some waves are able to travel through a vacuum through the vibrations of an electric and magnetic field. Visible light, infrared rays, microwaves and radio waves are examples of waves that travel through a vacuum. Waves that do not travel through a medium or travel in vacuum are called **electromagnetic waves**. Note that electromagnetic waves can also travel through a medium.

There are two main types of mechanical waves. One is **transverse wave** and other is **longitudinal wave**.

Transverse waves are types of waves in which the movement of the particles of the medium is at right angle to the direction of the of the wave motion resulting in the wave having high and low energy points. The high energy point in the transverse wave is termed as the **crest** and the low energy point is termed as **trough**.

Longitudinal waves are waves in which the movement of the medium is parallel to the direction of the movement of the waves.

Waves are very important to both humans and animals. Most of our everyday activities depend on it. The transmission of information (communication) is in the form of waves. For instance you are able to listen to your audio music tracks and even watch videos on TV because of waves. Cooking, talking and seeing is also made possible because of waves.

Animals also use wave motion for body waste removal and movement (navigation) through their surroundings. For instance eels and snakes use transverse body waves to push against the water or ground to help them move and earthworms use longitudinal waves for their movement. Bats and hammerhead sharks use waves to navigate in the night.



Learning Outcomes

After going through this module, you are expected to:

- define wave.
- differentiate wave types.
- generate waves using ropes and springs.
- describe the difference between transverse and longitudinal waves in terms of particle motion.
- differentiate mechanical and electromagnetic waves.
- give examples of transverse and longitudinal waves.
- apply mathematical formulae in determining wave properties which include amplitude, wavelength, period and frequency.
- describe relationship between frequency and period from

$$T = \frac{1}{f}$$

- draw wave diagrams from given parameters .
- demonstrate that waves are in phase or out of phase with respect to a reference wave.
- describe when two waves interfering constructively or destructively when they come together.
- apply mathematical formulae to calculate unknown quantities of a given wave using the wave equation:

$$v = f \times \lambda = f\lambda$$

- explain what light is in terms of waves.

Snell's Law: $\frac{n_1}{n_2} = \frac{\sin r}{\sin i}$ or $n_1 \sin i = n_2 \sin r$

- demonstrate an understanding of practical applications of
 - i) total internal reflection in periscopes, prisms, optic fibres and endoscope just to name a few.
 - ii) effect of refraction; determining real depths and apparent depths of objects underwater.
- research and recognize that sound energy can be transmitted by waves through solid, liquid and gases.



Time Frame

Suggested allotment time: **9 weeks**

This module should be completed within 9 weeks.

If you set an average of 3 hours per day, you should be able to complete the module comfortably by the end of the assigned week.

Try to do all the learning activities and compare your answers with the ones provided at the end of the module. If you do not get a particular question right in the first attempt, you should not get discouraged but instead, go back and attempt it again. If you still do not get it right after several attempts then you should seek help from your friend or even your tutor.

DO NOT LEAVE ANY QUESTION UNANSWERED.



12.3.1 Properties of Waves

We all have observed waves in our everyday lives in many contexts. We watched water waves propagated (created) away from boats or raindrops into still pools. We often listen to sound waves (music) generated by waves created on stretched guitar strings. We are reading the words in this module by means of light, an electromagnetic wave.

To understand more about waves, we can create our own wave in the laboratory by carrying out simple activities. Waves can be propagated in the laboratory or even outdoors from simple equipment like a rope or a spring. A dish of water from the kitchen and a pebble can also be used to generate waves from which the properties of waves can also be observed.

Activity 1: Wave propagation and energy transfer.

Aims:

1. To determine how a water wave is created.
2. See energy transfer in a wave motion.

Materials needed:

Kitchen dish, water, pebble (50 g), small floater, ruler, stop watch

Procedure:

1. Fill the kitchen dish halfway to the brim.
2. Let the water settle down, ensuring that the surface of the water in the dish is still, and undisturbed.
3. Place the small floater onto the water and let it float.
4. Hold the pebble 10 cm above the centre of the dish (use the ruler for the height).
5. Drop the pebble into the water in the dish.
6. Observe and record your observations under Results.

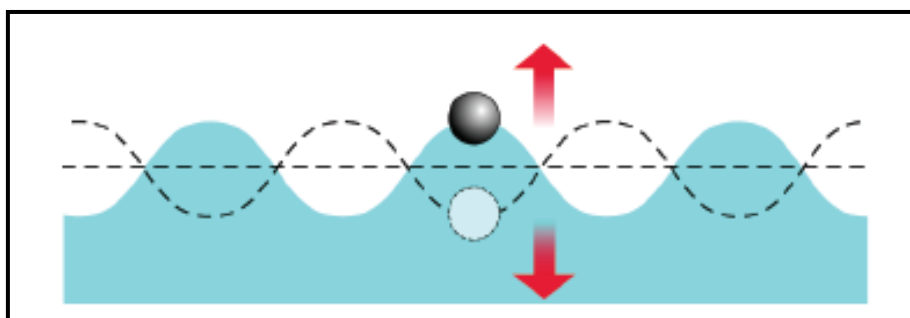

Results:

1. As a result of step 5, what did you observe?



2. What created the wave on the water surface as observed?

3. Describe the motion of the floater in relation to the direction of the wave.

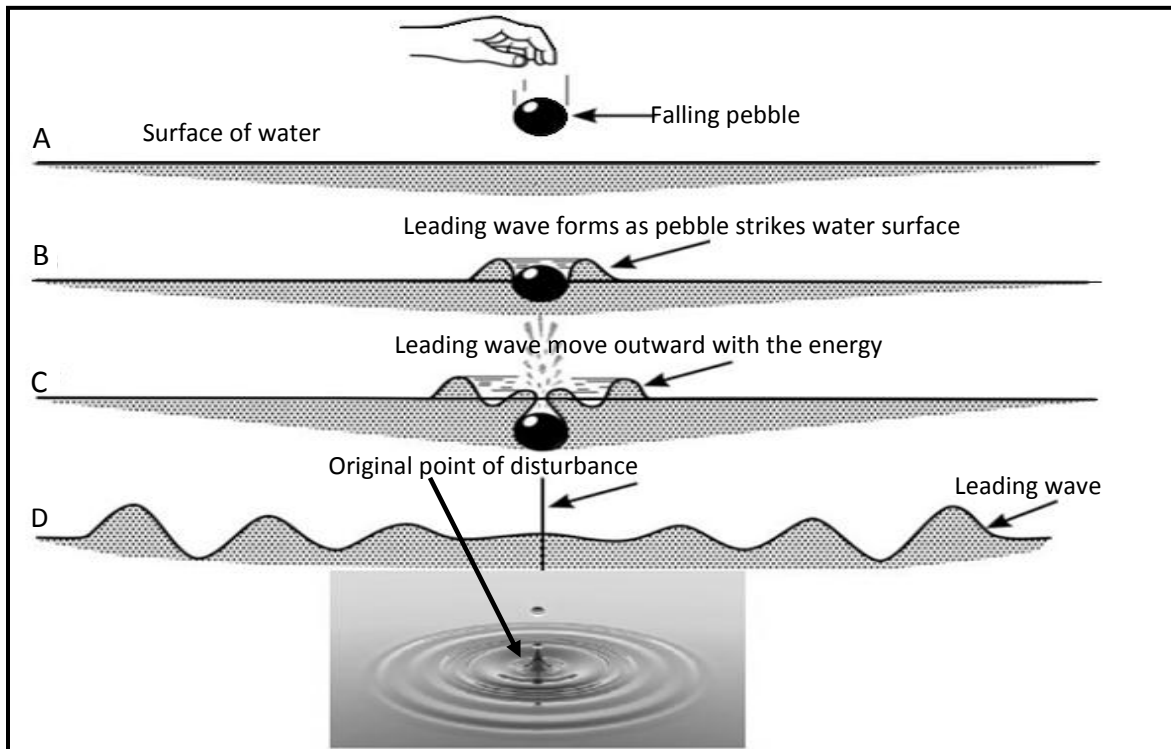

Figure 1: Wave propagation using a pebble dropped onto still water.

Conclusion:

The pebble at the height of 10 cm possesses gravitational potential energy (G.P.E). When the pebble was released, the G.P.E changes to kinetic energy due to the motion of the released pebble. As the pebble hits the surface of the water, the kinetic energy from the falling pebble is transferred to the surface of the water. This creates the vibration on the water surface which generates the waves. The waves then transfer the energy through the ripples (wave forms) outwards from the point of disturbance. The small floater goes up and down in the wave but does not move in the direction of the wave. This indicates that the wave motions only transfer energy and not the particles of the medium (water). The matter particles only vibrate but go back to their equilibrium position.

Remember these:

- The source of a wave is a vibration or oscillation.
- Waves transfer energy from one point to another.
- In waves, energy is transferred without the medium being transferred.

Types of Waves

Types of waves according to methods of energy transfer

When waves are classified according to their method of transfer of energy, there are two types, **mechanical** and **electromagnetic waves**.

Mechanical waves

A mechanical wave is a wave that is an oscillation of matter, and therefore transfers energy through a medium. Mechanical waves originate in an elastic material medium (air, steel and water). Properties which are responsible for transmission of mechanical waves in a medium are elasticity and density of the medium.

Some examples of mechanical waves are: vibration of string, the surface wave produced on the surface of solid and liquid (water), sound waves, tsunami waves, earthquake P-waves, ultra sounds, vibrations in gas, and oscillations in spring, internal water waves, and waves in a slinky spring coil.

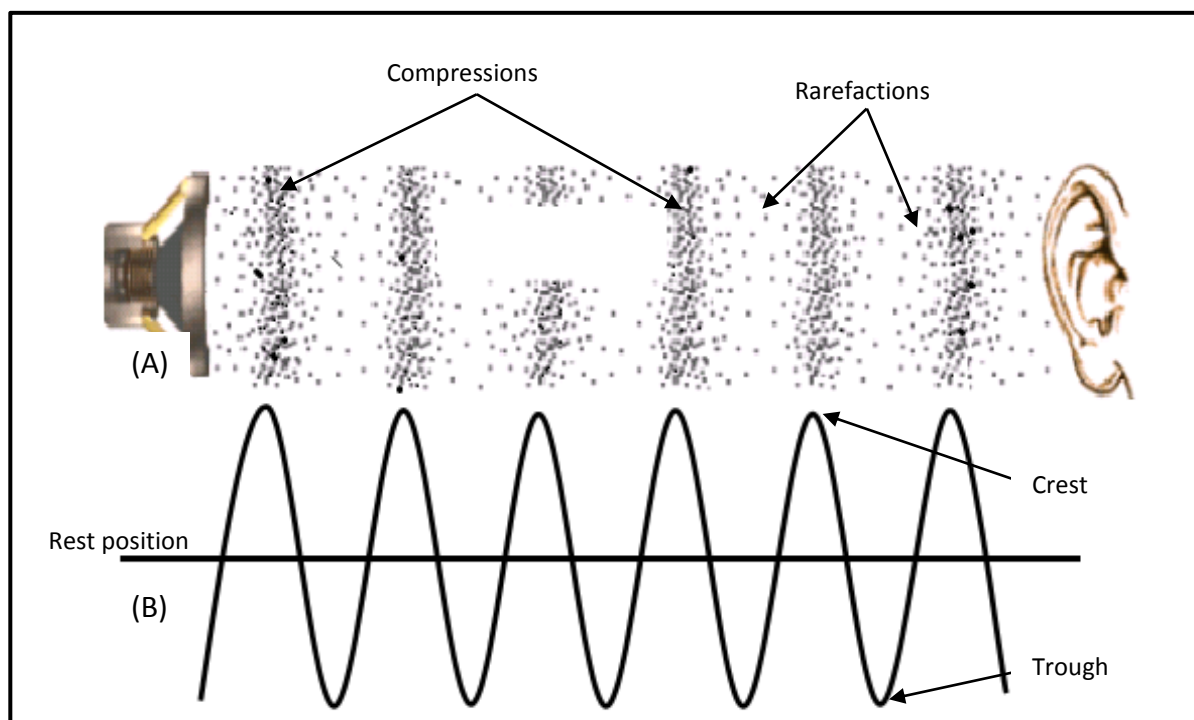

Figure 2: (A) Longitudinal wave and (B) Transverse wave are mechanical waves.

A wave that requires a **medium** to propagate is called a **mechanical wave**.



Electromagnetic waves

Electromagnetic (EM) waves are caused by varying electric and magnetic fields. As a result of the varying magnetic and electric fields a periodic change takes place creating the EM waves. Electromagnetic waves do not require any medium for its propagation and can travel through vacuum.

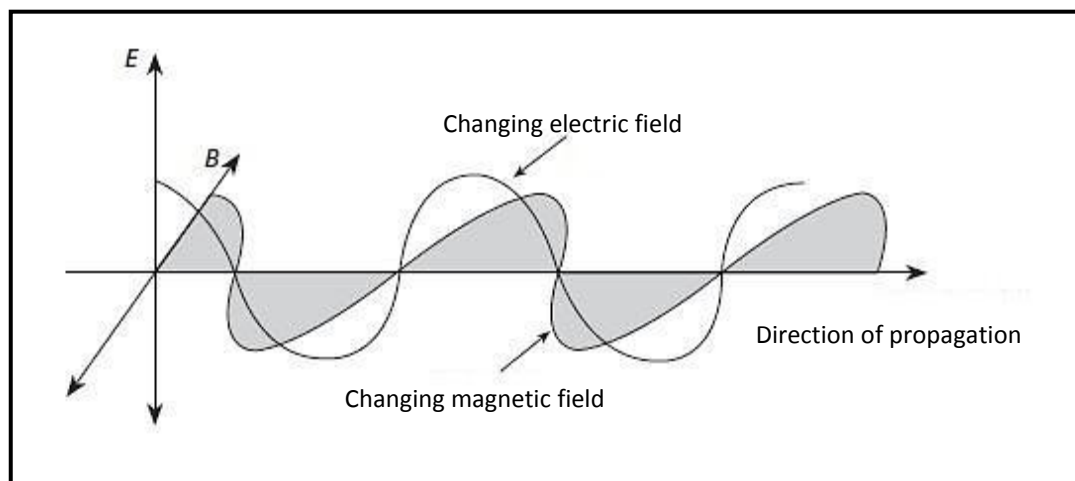

Figure 3: Electric and magnetic fields of an electromagnetic wave.

Electromagnetic radiation is the transmission of energy in the form of waves having both an electric and a magnetic component. It is not possible for a wave with just one of these components to exist. The most familiar forms of electromagnetic radiation are radio waves and light waves. Less familiar forms are infrared radiation, ultraviolet light, X-rays, and gamma rays, all of which constitute the electromagnetic spectrum.

Properties:

1. In vacuum, Electromagnetic (EM) waves travel with the velocity of light ($3 \times 10^8 \text{ms}^{-1}$).
2. EM waves can be polarized.
3. EM waves are transverse in nature.
4. Medium is not required for propagating the EM waves.
5. EM waves have momentum.

A wave that travels in a vacuum or empty space without a medium is called an electromagnetic wave.

Two main types of wave motion



The two main type of wave motion are the transverse and longitudinal waves. They can be described in relations to the motion of the:

1. wave's energy and
2. individual molecules (particles) of the wave.

Transverse wave

Activity 2: Energy transfer from a transverse wave propagated from a rope.

Aims:

1. To propagate transverse waves using a rope.
2. To identify the direction of the wave motion and the particle disturbance.

Materials needed:

Rope (5m), coloured ribbon

Procedure:

1. Tie one end of the rope fixed to a wall or tree at waist height.
2. Tie the ribbon in the centre of the rope.
3. Hold the other end and pull it till it's stretched out in a rest equilibrium position.
4. Move the end of the rope you are holding in a repeated up and down motion.
5. Observe what you see and record it under Results.
(Refer to the diagram before the conclusion which shows all procedures and answer the questions in the results below)

Results:

1. As a result of step 4, what did you observe?

2. What created the wave on the rope as observed?

3. Does the attached ribbon move from its centre position to the end of the rope?

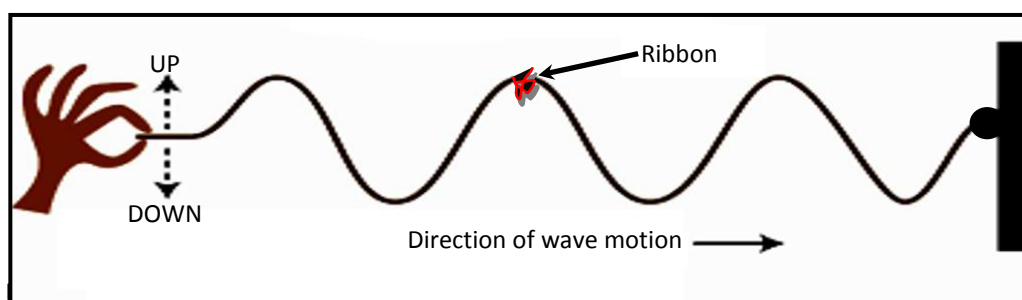

Conclusion:



The up and down motion of the hand creates the disturbance to the straight rope. This disturbance causes the rope to vibrate and generate a waveform. The kinetic energy from the up and down motion of the hand is transferred from one end of the rope to the fixed end. When rope is moving in its up and down waveform noticed that the ribbon only moves up and down but does not move to the fixed end of the rope. This indicates that the wave motions only transfers energy and not the matter (rope) particles. The matter particles only vibrate but go back to their equilibrium position. Notice the motion of the vibration is up and down while the motion of the wave travels perpendicular to the vibration.

In a transverse wave, the two motions are perpendicular to each other. This means that the particles of the medium vibrate at right angles (90°) to the direction in which the wave travels or the direction of transfer of energy.

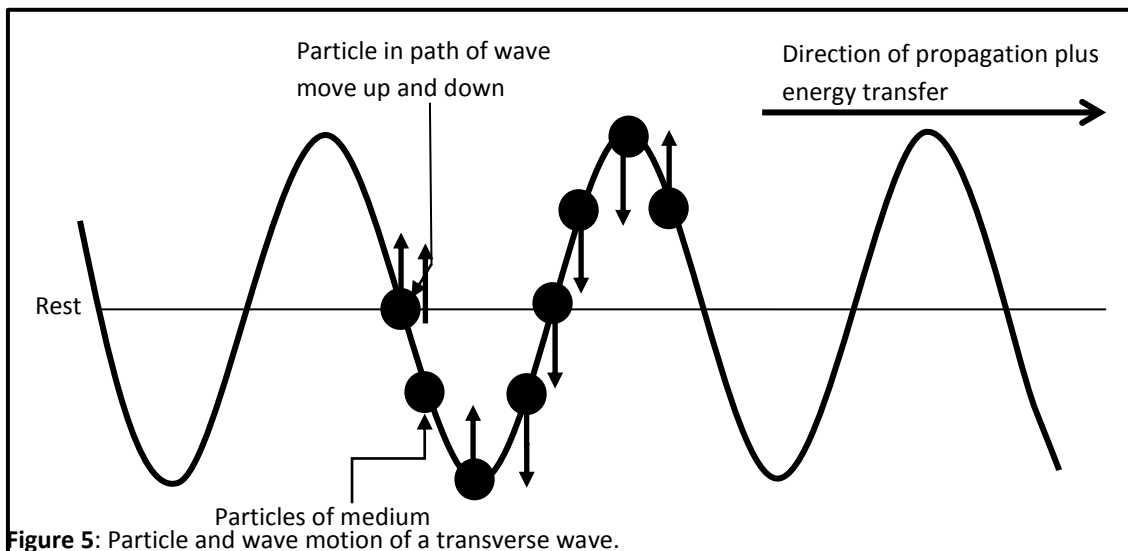

A transverse wave is a wave that travels in the direction perpendicular to the direction of vibration or oscillation.

Examples of transverse wave

i) Water waves

Water waves are an example of transverse waves. A transverse wave consists of a high part or peak called **crest** and a low part called **trough**.

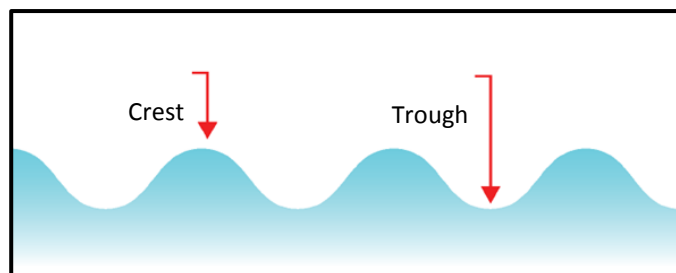

Figure 6: Transverse waves in vibrating water waves.

ii) Rope/spring wave

A quick series of flips sends a succession of pulses toward the post. Obviously, the rope itself does not move forward and any particle in it undergoes only up-and-down motion thus the disturbance caused at one end is conveyed to the other by a transverse wave.

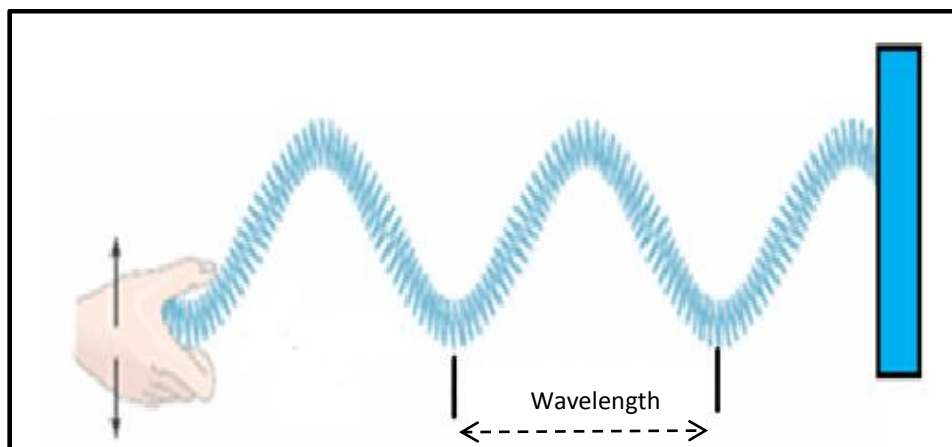

Figure 7: Vibration of a spring or a rope propagates a transverse wave.

All electromagnetic waves are transverse waves; they do not require a medium and can travel in a vacuum. Transverse waves are waves in which the particles of the medium move at right angle to the wave direction.

Longitudinal wave

Activity 3: Energy transfer from a longitudinal wave propagated from a spring (slinky).

Aims:

1. To propagate longitudinal waves using a spring (slinky).
2. To identify the direction of the wave motion and the particle disturbance.

Apparatus needed:

Spring (slinky), ribbon

Procedure:

1. Attach one end of the spring to a fixed position.
2. Stretch the spring to a length of 5 m.
3. Tie the ribbon in the centre of the spring.
4. Move the free end of the spring in a forward and backward motion (push and pull) to compress and expand the spring respectively.
5. Observe what you see and record it under Results.

Results:



1. As a result of step 4, what did you observe?

2. What created the wave on the rope as observed?

3. Does the attached ribbon move from its centre position to the end of the rope?

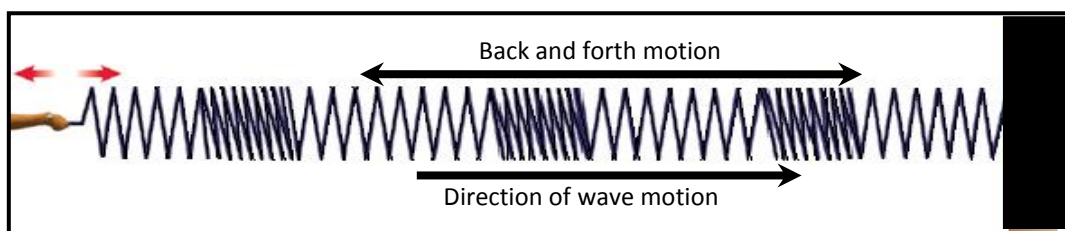

Figure 8: A boy generating longitudinal waves using a slinky.

Conclusion:

The back and forth (push and pull) motion of the spring creates a disturbance. This disturbance causes the coils of the spring to vibrate and generate a compression and expansion waveform. The kinetic energy from the push and pull motion of the hand is transferred from free end of the spring to the fixed end. When the spring is moving in its back and forth waveform, noticed that the ribbon only moves parallel to the motion of the wave but does not move to the fixed end of the spring. This indicates that the wave motions only transfers energy and not the matter (spring) particles. The matter particles only vibrate but go back to their equilibrium (rest) position.

It can be concluded from the three simple activities that the source of a wave is a vibrations or oscillation. The energy from the vibration creates a disturbance and the disturbance carries the energy from one place to another through a medium or without a medium at times. It is important to note that only energy is transferred by the wave and **not** matter in the medium.

In a longitudinal wave, the motion of the wave energy and particle motion are parallel to each other. This means that the particles of the medium vibrate back and forth in the same direction in which the wave travels and transfer energy.

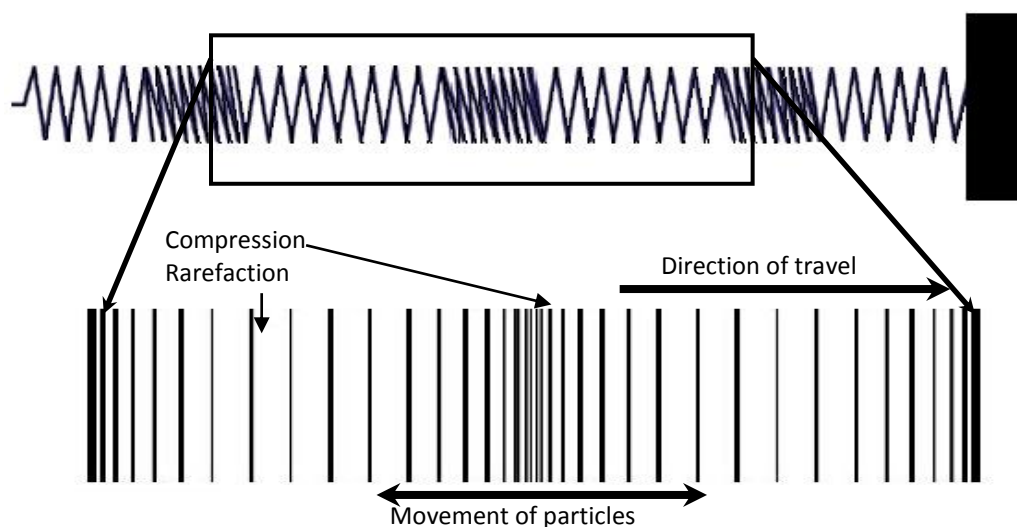

Figure 9: Particle motion and wave travel of longitudinal waves.

A longitudinal wave is a wave that travels in the direction parallel to the direction of vibration or oscillation.

An example of longitudinal wave is sound wave

Sound waves are made up of regions where the air molecules are close together and have a higher particle density known as **compressions** and of regions where the air molecules are farther apart and have a low particle density called **rarefactions**. In a sound wave the region of compression is at a slightly higher pressure due to the air molecules being pushed together whereas the region of rarefaction is at a slightly lower pressure as the air molecules are farther apart.

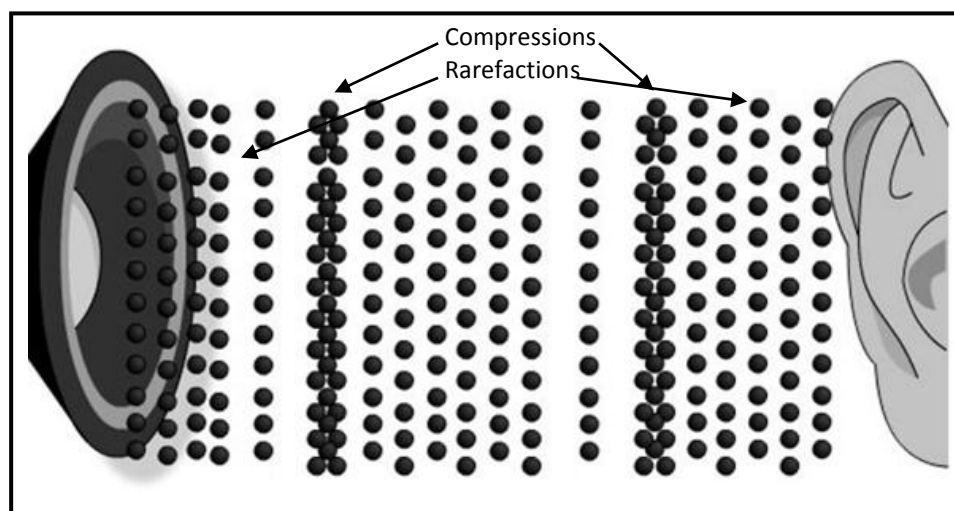

Figure 10: Side view of sound wave.



Energy is passed along the air molecules by the lengthways vibration of the air molecules. Thus the air molecules only move to and fro or forwards and backwards in the direction of travel of the wave. The sound energy is transferred from one molecule to another and so it travels along the wave.

Other examples of longitudinal waves include tsunami waves, earthquake, P – waves, ultra sounds, vibrations in gas, internal water waves, and waves in slink.

Now check what you have just learnt by trying out the learning activity below.

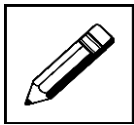

Learning Activity 1



10 minutes

Answer the following questions on the spaces provided.

For Questions 1 – 3, fill in the missing space with the correct word.

1. A disturbance that transfers energy from one place to another is called a _____.

2. The type of wave which the wave motion is perpendicular to the direction of the vibration of particles is called _____ wave.

3. Sound wave is an example of a _____ wave.

For Questions 4 – 8, write your answers on the spaces provided.

4. Name the two characteristics that describe transverse and longitudinal wave motions.

a) _____

b) _____

5. Name three examples of mechanical waves.

a) _____

b) _____

c) _____



6. Differentiate between a transverse and a longitudinal wave.

7. When waves travel energy is transferred from one place to the next. What happens to the particles of the medium during energy transfer?

Refer to the diagram below to answer Question 8 .

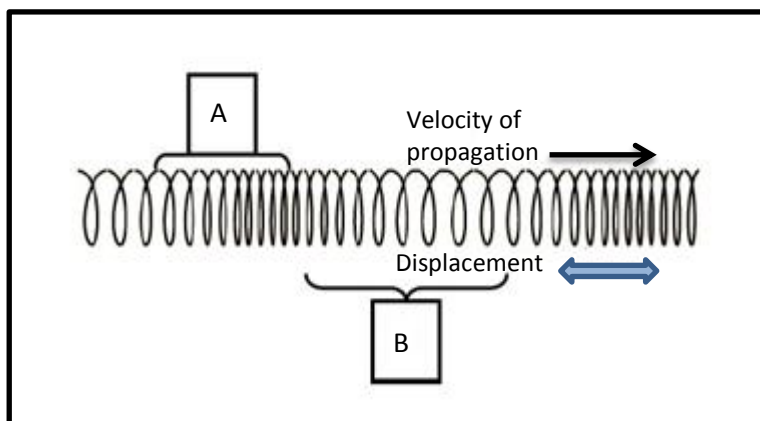

8. (a) What part of the wave is labelled A? _____
- (b) What part of the wave is labelled B? _____
- (c) What type of wave is shown in the diagram? _____

Thank you for completing learning activity 1. Now check your work. Answers are at the end of the module.



Wave Properties

Periodic wave motions are those that are continually produced by a source. The properties of these wave motion can be described using certain terms.

Crest and trough

These are the highest and the lowest points of a transverse wave respectively. A **crest** is a point on the wave where the displacement of the medium is at a maximum. A **trough** is a point on the wave where the displacement of the medium at that point is at a minimum.

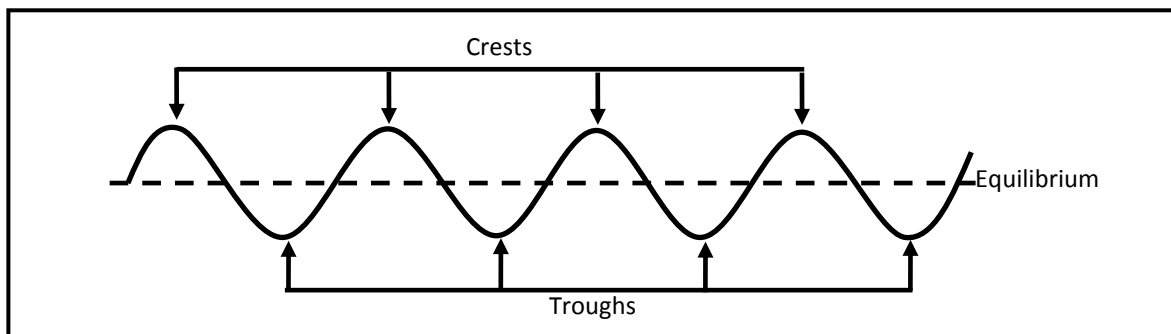

Figure 11: Crests and troughs on a transverse wave.

Compressions and rarefactions

A **compression** is a region in a longitudinal wave where the particles are closer together (compressed). A **rarefaction** is a region in a longitudinal wave where the particles are further apart (expanded).

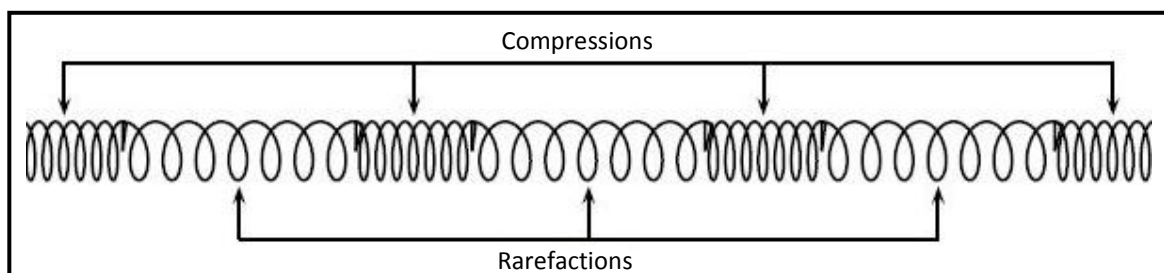

Figure 12: Compressions and rarefactions on a longitudinal wave.

Wavelength (λ)

This is the shortest distance between any two points in a wave that are in phase, which can be the distance between two successive crests, two successive trough or any two points which are in phase for a transverse wave.

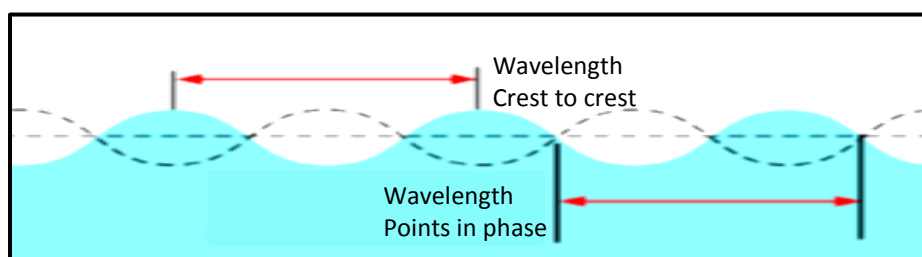

Figure 13: Wavelength of a transverse wave.

For longitudinal waves it is the distance between two successive compressions or rarefactions. Wavelength is measured in metres (m).

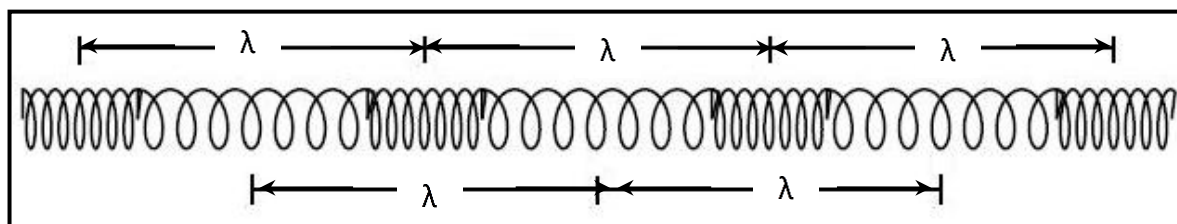

Figure 14: Wavelength of a longitudinal wave.

Amplitude (A)

This is the maximum displacement from the rest or equilibrium position. It is the height of a crest or depth of a trough measured from the rest position. The higher the amplitude, the more energy the wave possesses. Amplitude is measured in metres (m).

Example 1

A mass is tied to a spring and begins vibrating periodically. The distance between its highest position (crest) and its lowest position (trough) is 38 cm. What is the amplitude of the vibrations?

Solution: 19 cm

The distance that is described is the distance from the high position to the low position. The amplitude is from the middle position to either the high or the low position.

Example 2

A teacher attaches a slinky to the wall and begins introducing pulses with different amplitudes. Which of the two pulses (A or B) below will travel from the hand to the wall in the least amount of time? Justify your answer.

Solution

Both A and B will reach the wall **at the same time**. The amplitude of a wave does not affect the speed at which the wave travels. Both Wave A and Wave B travel at the same speed. The speed of a wave is only altered by alterations in the properties of the medium through which it travels.

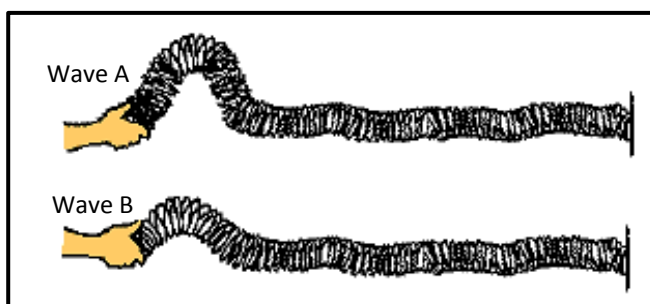

Period (T)

The period of a wave is the time (**in seconds**) taken by the wave to move one wavelength. It is the time taken for one point on the wave to complete one oscillation or the time taken to produce one complete wave. A complete wave is made up of a crest and a trough.

Frequency (f)



The frequency of a wave is the number of wavelengths per second. It is the number of complete waves produced in one second. The SI unit for frequency is hertz (Hz) which is oscillation per second.

We can relate frequency to period using the following equations:

$$f = \frac{1}{T} \quad T = \frac{1}{f}$$

Notice from the equations that period is the inverse of frequency and vice versa. Therefore a higher **frequency (f)** implies that more waves are produced in one second. When this happens, the **period (T)** will be shorter.

Example 1

Linda is reported to have clapped her hands 336 times in 60.0 seconds. What is the frequency and what is the period of Linda's hand clapping during this 60.0 second period?

Solution

In this problem, the event that is repeating itself is the clapping of hands; one hand clap is equivalent to *a cycle*.

Frequency = cycles per second

$$\begin{aligned} f &= \frac{\text{claps}}{\text{time}} & T &= \frac{1}{f} \\ f &= \frac{336}{60.0} & T &= \frac{1}{5.6} \\ f &= 5.6\text{Hz} & T &= 0.1786\text{s} \end{aligned}$$

Example 2

A pendulum is observed to complete 20 full cycles in 10 seconds. Determine the period and the frequency of the pendulum.

Solution

The frequency can be thought of as the number of cycles per second. Calculating frequency involves dividing the stated number of cycles by the corresponding amount of time required to complete these cycles. In contrast, the period is the time to complete a cycle. Period is calculated by dividing the given time by the number of cycles completed in this amount of time.

$$\begin{aligned} f &= \frac{\text{cycles}}{\text{time}} & T &= \frac{1}{f} \\ f &= \frac{20}{10} & T &= \frac{1}{2} \\ f &= \mathbf{2\text{Hz}} & T &= \mathbf{0.5\text{s}} \end{aligned}$$

Displacement – distance graph

The **wavelength** (λ) and the **amplitude** (A) of a transverse rope wave can be represented using a displacement distance graph. **Displacement – distance graph**

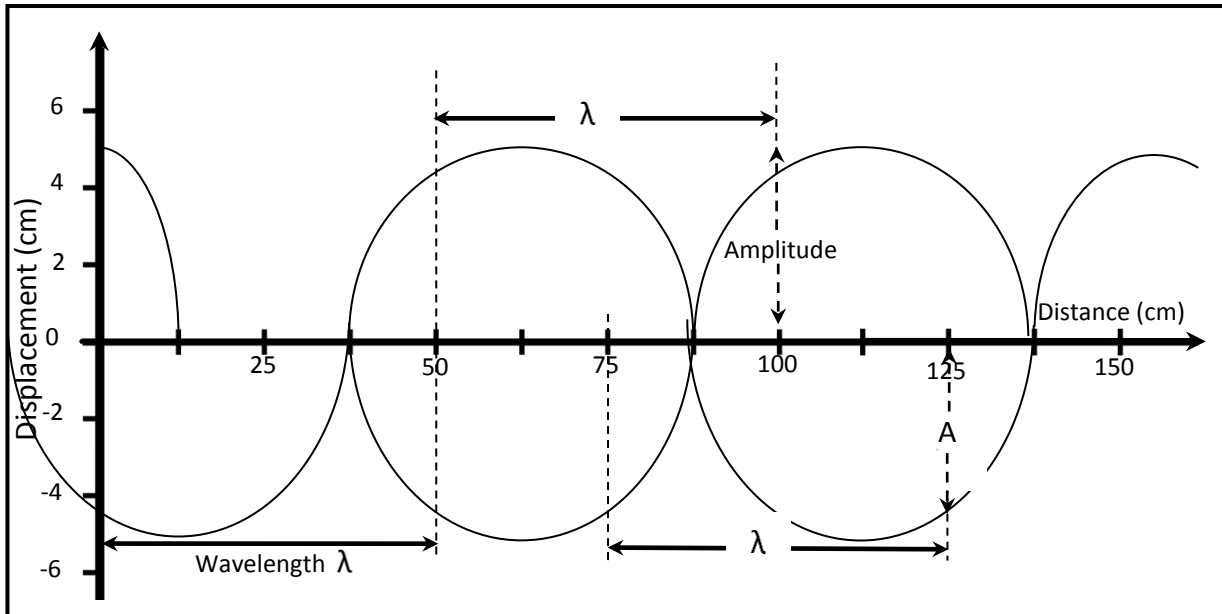

Figure 15: A displacement – distance graph showing amplitude and wavelength.

Displacement – time graph

If you ‘freeze’ the wave motion of a rope is at various times, the up and down movement of points can be observed to determine the time for one complete wavelength in order to calculate the speed of a wave.

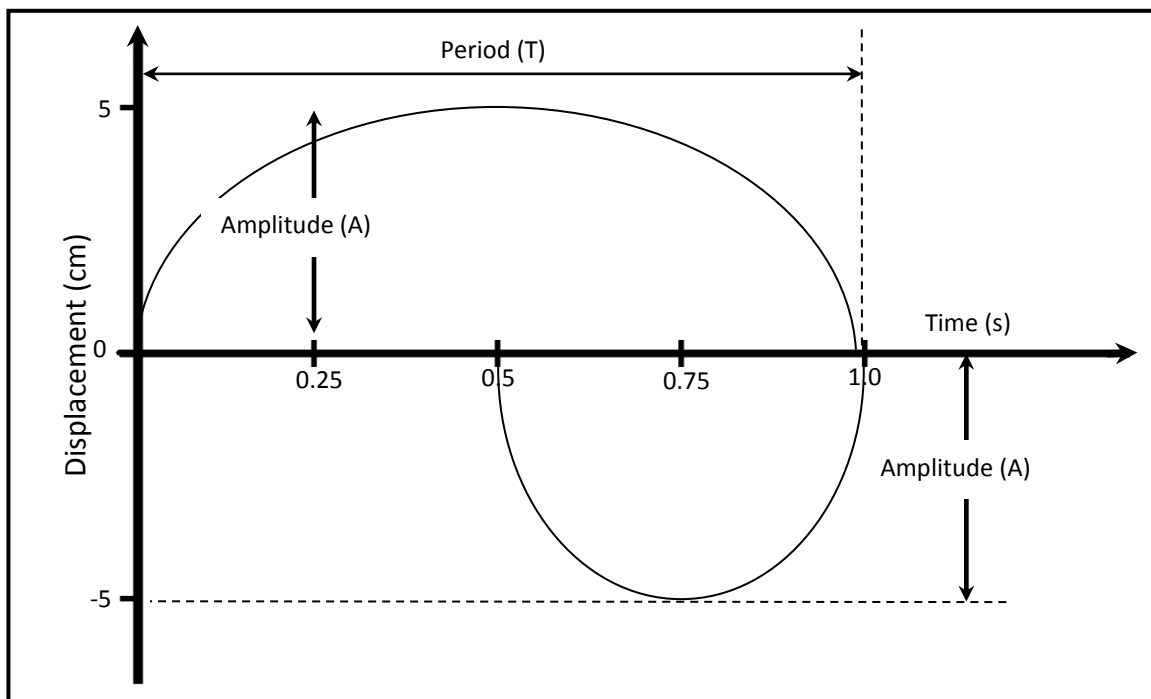

Figure 16: Displacement – time graph showing the period for a complete wavelength.

**Wave speed (v)**

In a time of one **period** (T), a crest on a transverse wave will move a distance of one **wavelength** (λ).

Therefore, the speed of a wave is given by:

$$\text{speed} = \frac{\text{distance}}{\text{time}}$$
$$\text{wavespeed} = \frac{\text{wavelength}}{\text{period}}$$
$$v = \frac{\lambda}{T} \quad \text{Since } T = \frac{1}{f}$$
$$v = f\lambda$$

Where

v is the wave velocity in metres per second (m/s)

λ is the wavelength in metres (m)

T is the period in seconds (s)

f is the frequency in (Hz)

All waves (transverse and longitudinal) obey this wave equation. $v = f\lambda$

Example 1

A wave with a frequency of 100 Hz and a wavelength of 2 m travels towards the shores, What is the speed of the waves?

$$v = f\lambda$$
$$v = 100 \times 2$$
$$v = \mathbf{200\text{ms}^{-1}}$$

Example 2

What is the time required for the sound waves to travel from the tuning fork to a point A as shown in the diagram on the right? Note that speed of sound in air is 340 m/s.

Solution

$$v = 340\text{m/s}, d = 20\text{m} \text{ and } f = 512\text{Hz}$$

$$v = \frac{d}{t}$$

$$t = \frac{d}{v}$$

$$t = \frac{20}{340}$$

$$t = \mathbf{0.59\text{s}}$$

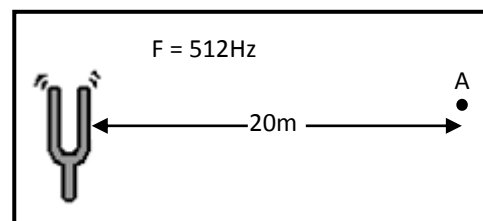

**Example 3**

Lisa and Joy are floating on top of the water near the end of the pool when Lisa creates a surface wave. The wave travels the length of the pool and back in 25 seconds. The pool is 25 metres long. Determine the speed of the wave.

Solution

$$d = 50\text{m (1-way=25m)}, t = 25\text{s (total time of travel)}$$

$$v = \frac{d}{t}$$

$$v = \frac{50}{25}$$

$$v = 2\text{ms}^{-1}$$

Example 4

A hummingbird beats its wings at a rate of about 70 wing beats per second. What is the frequency in Hertz of the sound wave? Assuming the sound wave moves with a velocity of 350m/s, what is the wavelength of the wave?

Solution

$$f = 70\text{Hz and } v = 350\text{m/s}$$

$$\lambda = \frac{v}{f}$$

$$\lambda = \frac{350}{70}$$

$$\lambda = 5\text{m}$$

Example 5

A weather station observes a vertical distance from high point to low point of 4.6 metres and a horizontal distance of 8.6 metres between adjacent crests. The waves splash into the station once every 6.2 seconds. Determine the frequency and the speed of these waves.

Solution

$\lambda = 8.6\text{m}$, $T = 6.2\text{s}$. The wavelength is 8.6 metres and the period is 6.2 seconds.

$$f = \frac{1}{T}$$

$$f = \frac{1}{6.2}$$

$$f = 0.161\text{Hz}$$

$$v = f\lambda$$

$$v = \frac{\lambda}{T}$$

$$v = \frac{8.6}{6.2}$$

$$v = 1.4\text{m/s}$$

or

$$v = f\lambda$$

$$v = 0.161 \times 8.6$$

$$v = 1.4\text{m/s}$$

**Example 6**

Two boats are anchored 4 meters apart. They bob up and down, returning to the same up position every 3 seconds. When one is up the other is down. There are never any wave crests between the boats. Calculate the speed of the waves.

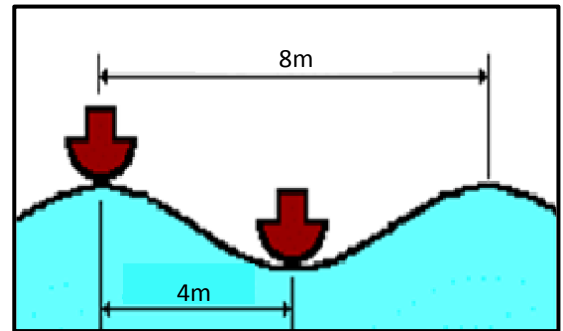
**Solution**

$$\lambda = 8\text{m}, T = 3\text{s}$$

$$v = \frac{\lambda}{T}$$

$$v = \frac{8}{3}$$

$$v = 2\frac{2}{3}$$

$$v = 2.67\text{m/s}$$

Now check what you have just learnt by trying out the learning activity below!

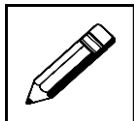
**Learning Activity 2**

40 minutes

Write your answers on the spaces provided

1. Identify and label parts of the waves shown below.

a)

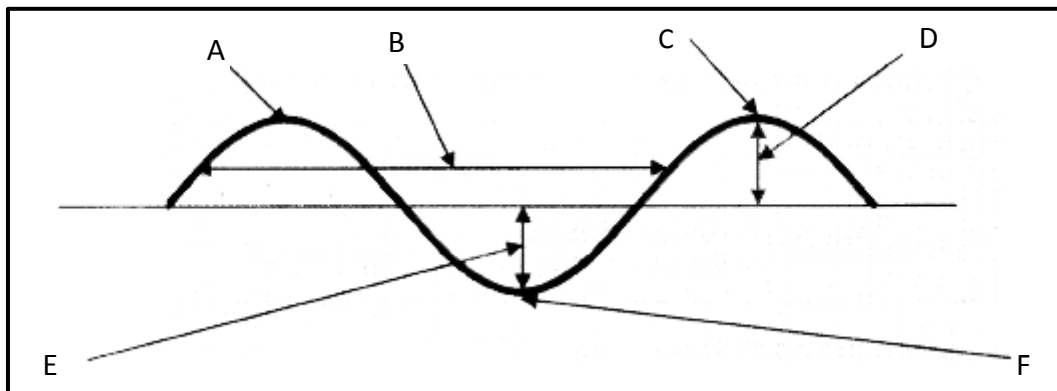

A. _____

C. _____

E. _____

D. _____

F. _____

B. _____



b)

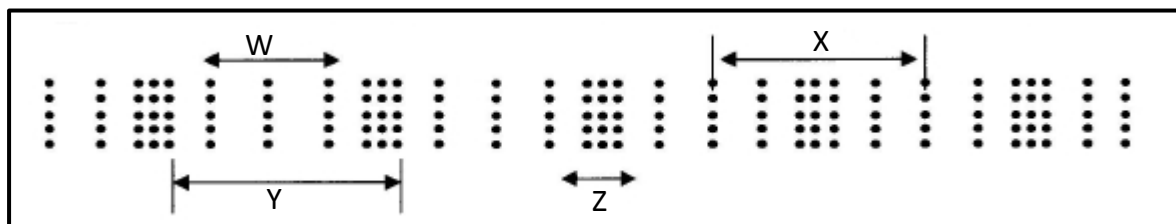

W. _____

X. _____

Y. _____

Z. _____

2. Sound travels through air at about 330ms^{-1} .

Calculate the wavelength of the sound of frequency 256Hz .

3. A piano has a frequency of 512Hz . Using the speed of sound in air, calculate its wavelength.

4. The speed of light is $3 \times 10^8\text{ms}^{-1}$. Violet light has a wavelength of about $4 \times 10^{-7}\text{m}$. Calculate the frequency of this light.



5. The diagram below shows a waveform.

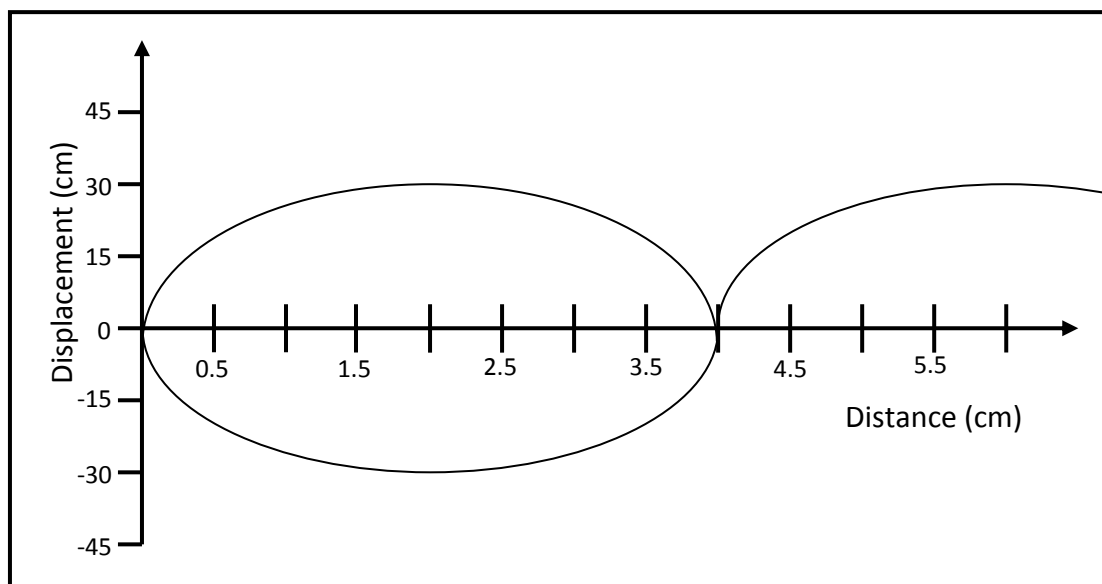

- a) What is the amplitude of the waveform?
-
- b) What is the wavelength?
-
- c) If the period of this waveform is 0.5s, what is its frequency?
-
- d) What is the speed of this waveform?
-

6. The table below shows information about the various colours of visible light. Calculate the missing data. Speed of light is 3×10^8 m/s.

Colour	Frequency (Hz)	Wavelength (nm)
Red		750
Orange		600
Yellow		580
Green		540
Blue	6.0×10^{14}	
Indigo	6.7×10^{14}	



7. The graph below shows the displacement of a particle in a wave of wavelength 4.0m.

Determine the period, frequency, amplitude and speed of the wave.

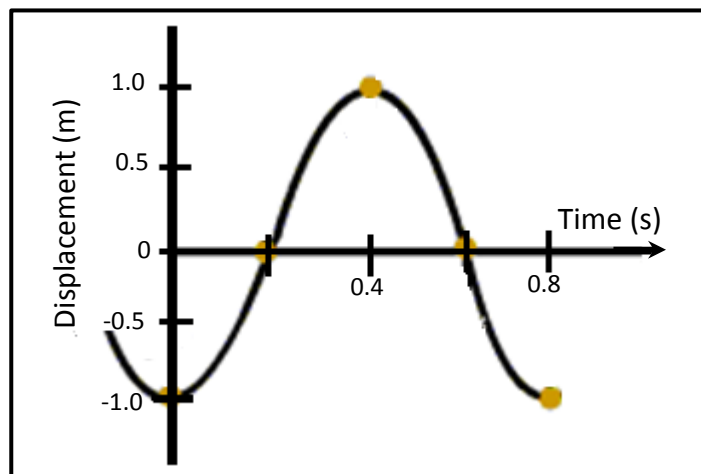

Period: _____

Frequency: _____

Amplitude: _____

Thank you for completing learning activity 2. Now check your work. Answers are at the end of the module.

12.3.2 Superposition and Interference of Waves

There are certain phenomena that waves experience when they encounter an obstacle or meet each other in a medium. When encountering a boundary, waves can undergo reflection, in which they meet the boundary and move back (bounce off), away from the boundary. If the wave travels at an angle to the normal when meeting the boundary, they bend or refract. Waves also experience diffraction which is changing of their direction as they pass from one medium to another.

If two waves meet interesting things can happen. Waves are basically collective motion of particles. So when two waves meet they both try to impose their collective motion on the particles. This can have quite different results.

The appearance of the medium during impact will be affected when waves meet while travelling either in the same or in opposite directions through the same medium. This is due to the forces the waves applied to one another because of the kinetic energy they possess. This pertains to the topic of superposition and interference of waves.



Superposition

When two or more waves arrive at the same point, they superimpose themselves on one another. More specifically, the disturbances of waves are superimposed when they come together—a phenomenon called superposition. Each disturbance corresponds to a force, and forces add. If the disturbances are along the same line, then the resulting wave is a simple addition of the disturbances of the individual waves—that is, their amplitudes add. The resulting amplitudes are obtained by using the **Principle of Superposition**.

The principle of superposition states that the effect of the pulses is the sum of their individual effects.

After waves pass through each other, each pulse continues along its original direction of travel, and their original amplitudes remain unchanged.

Phase

The alignment of two waves in space or time is a tricky thing to talk about. To save having to talk about 'troughs lining up with troughs' or 'crests lining up with crests' it is really useful to introduce the idea of phase.

Any two points on a wave are said to be **in phase** when they move in the same direction, have the same speed and the same displacement from the rest or equilibrium position at the same time. Any two crests or troughs are always in phase.

Sometimes they do not have to be successive crests or troughs, but they must be separated by a distance which is one complete wavelength. We then have an alternate definition of the wavelength as the distance between any two adjacent points which are in phase. Points that are not in phase are those that are not separated by a complete number of wavelengths, are called **out of phase**.

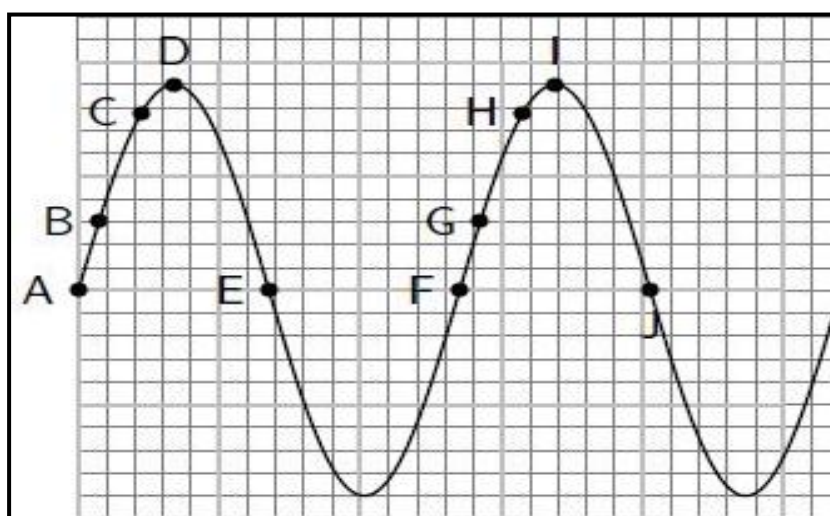

Figure 17: Points which are in phase and out of phase on a transverse wave.

Consider the diagram above that illustrates points on transverse waves which are in phase and out of phase. The points that are in phase are; **A to F, B to G, C to H, D to I, and E to J.**



Points in the waveform which are not in phase would be **A** and **C**, or **D** and **E**, or **B** and **H** in the diagram.

Interference

If two identical (same wavelength, amplitude and frequency) pulses of waves travelling in opposite direction towards each other meet at a point both will try to form a crest. They will be able to achieve the sum of their efforts. The resulting motion will be a crest which has a height that is the sum of the heights of the two wave pulses combined. If two wave pulses are both trying to form a trough in the same place then a deeper trough is formed, the depth of which is the sum of the depths of the two waves.

Now in this case, the two waves have been trying to do the same thing, and so add together constructively. This is called **constructive interference**. Constructive interference takes place when two wave pulses meet each other to create a larger pulse. The amplitude of the resulting wave pulse is the sum of the amplitudes of the two initial pulses.

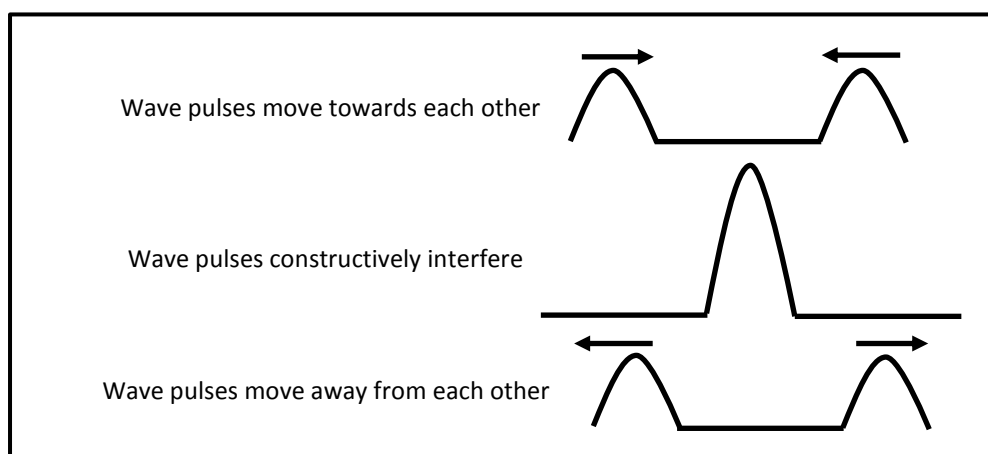

Figure 18: Constructive interference

Constructive interference is when two pulses meet, resulting in a bigger pulse.



When two pulses meet and cancel each other **destructive interference** takes place. The amplitude of the resulting pulse is the sum of the amplitudes of the two initial pulses, but the one amplitude will be a negative number. This is shown in Figure 19. In general, amplitudes of individual pulses add together to give the amplitude of the resultant pulse.

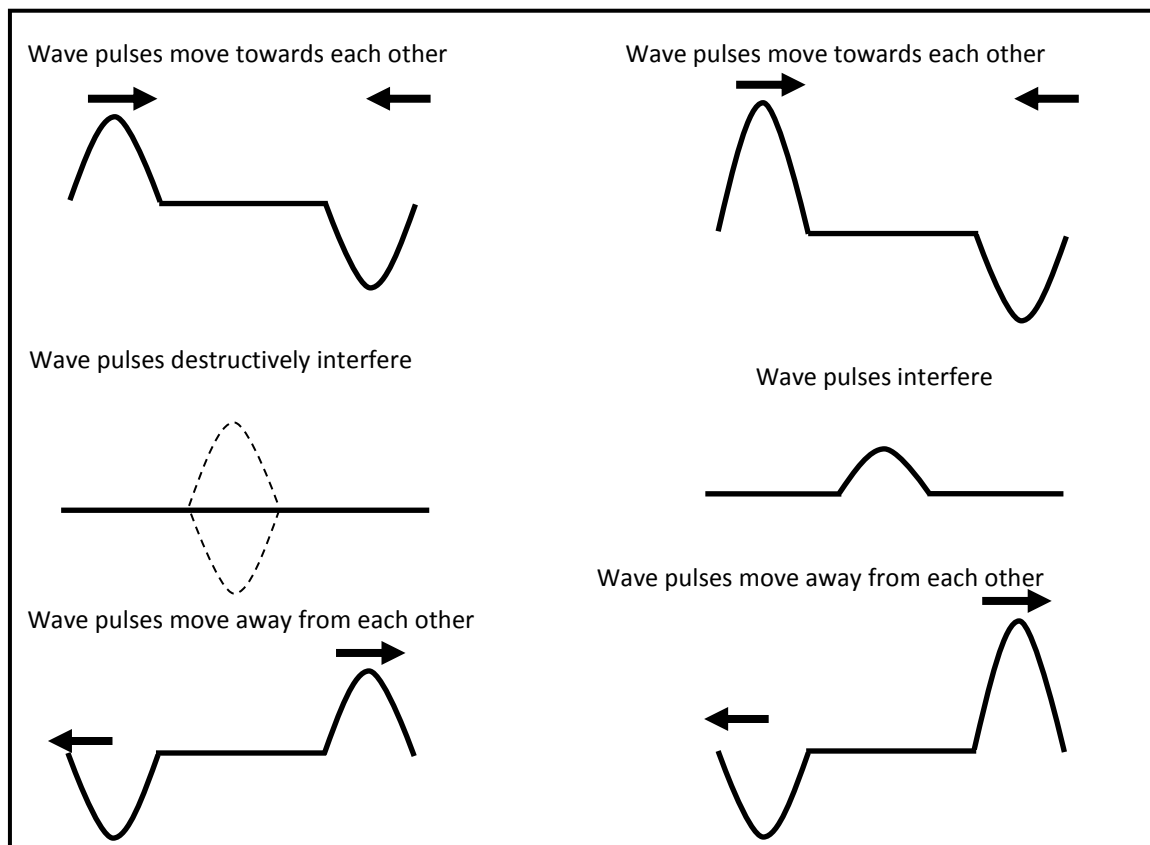

Figure 19: Destructive interference

Destructive interference is when two pulses meet, resulting in a smaller or no wave pulse.

Standing waves

Sometimes waves do not seem to move. Rather, they just vibrate in place. Unmoving waves can be seen on the surface of a glass of milk in a refrigerator, for example. Vibrations from the refrigerator motor create waves on the milk that oscillate up and down but do not seem to move across the surface. These waves are formed by the superposition of two or more moving waves, such as illustrated in the diagram below for two identical waves moving in opposite directions. The waves move through each other with their disturbances adding as they go by. If the two waves have the same amplitude and wavelength, then they alternate between constructive and destructive interference. The resultant looks like a wave standing in place and, thus, is called a **standing wave**.

Waves on the glass of milk are one example of standing waves. There are other standing waves, such as on guitar strings and in organ pipes. With the glass of milk, the two waves that produce standing waves may come from reflections from the side of the glass.

Waves on the glass of milk are one example of standing waves. There are other standing waves, such as on guitar strings and in organ pipes. With the glass of milk, the two waves that produce standing waves may come from reflections from the side of the glass.

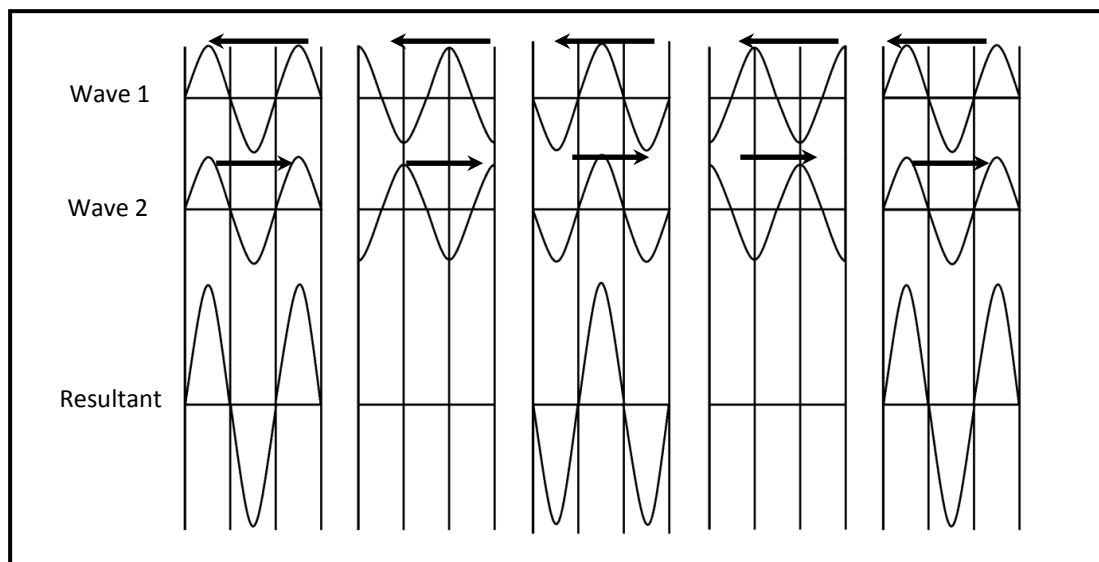

Figure 20: Standing waves.

Interference of water waves

When waves meet they may reinforce or cancel each other out (superposition), but then continue on as though they had not met. If they are the same shape, and amplitude, and on the same side, they will **constructively interfere** to produce a wave of twice the amplitude, an **antinode**.

If they are on opposite sides they will **destructively interfere**, cancelling each other out, producing a **node**. Two-dimensional water waves undergo the same phenomena but the pattern is more complicated as the waves from two sources radiate outward in all directions.

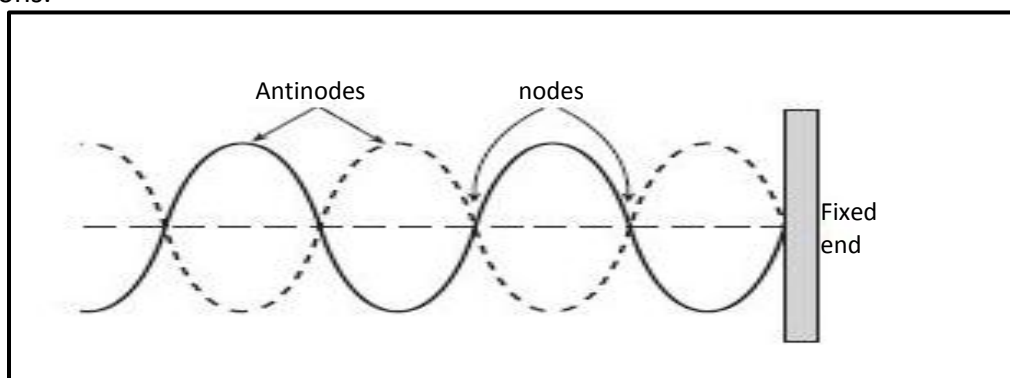

Figure 21: A standing wave produced by the continual generation and reflection of waves off a fixed wall. Oscillation only occurs between the dashed and solid lines.

A ripple tank can be used to produce waves which are in phase and having identical amplitudes by using two identical dippers attached to the wave generator. When the electric motor vibrates (moves up and down in water) the two dippers' in and out motion of with the water, will produce two sets of circular radiating waves that are in phase and of the same amplitude. Another term for in-phase is **coherent**.



As the waves move outward, a crest from one dipper will meet a crest from the other, and constructive interference occurs, producing a larger crest. The same happens when a trough from one meets a trough from the other. When a crest from one meets a trough from the other, destructive interference occurs and the waves cancel. As the waves radiate outward they continue to add and cancel. The resulting pattern that occurs is the characteristic interference pattern produced by two sources in phase as shown below.

It will be noticed in this photograph that there are regions that are bright, dark and grey. The grey or shadow areas are areas where cancellation has occurred, that is, where a trough from one source cancels a crest from the other. A bright area is where two crests met, producing a larger crest.

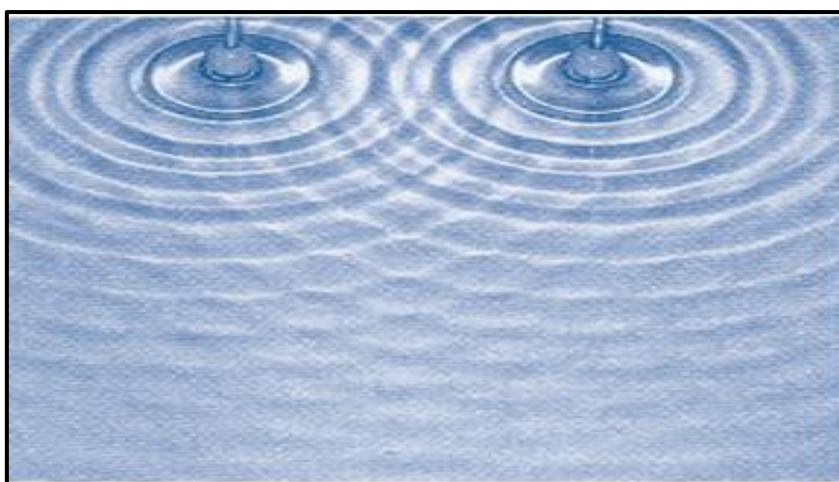

Figure 22: Interference produced by two sources of waves in a ripple tank.

The resulting pattern can be drawn schematically with lines through the grey areas of undisturbed water, as shown in figure 23. These lines are called **nodal lines**. Lines can also be drawn through the bright and dark regions — regions of constructive interference. These are **antinodal lines**.

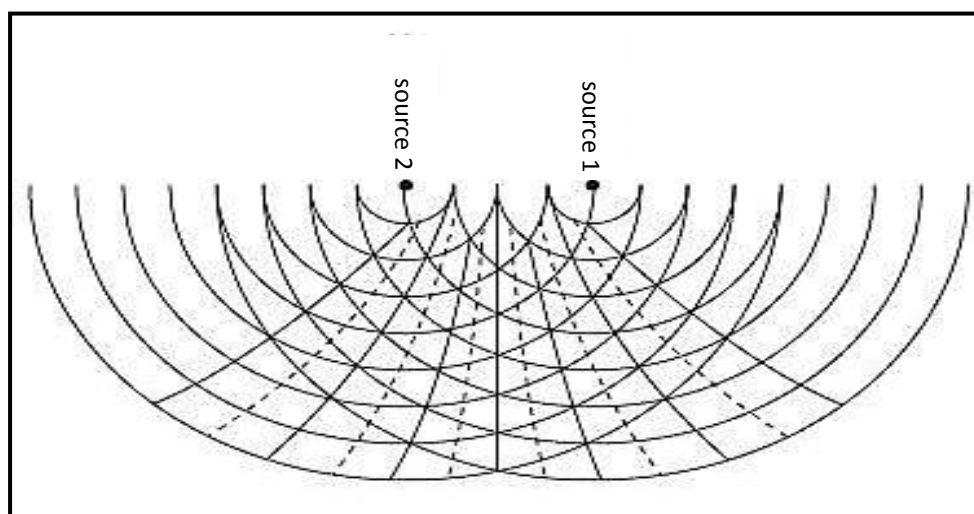

Figure 23: The constructive and destructive interference pattern produced by waves from two sources.



You may understand this well when we consider some points on the pattern (figure 24). Consider point X on the central antinodal line (**the central maximum**). This point is a distance of S_1X from source S_1 and a distance S_2X from source S_2 . It will be noticed that X is 3λ from S_1 and is 3λ from S_2 . The difference in distance from the two sources, the **path difference (PD)**, is zero wavelengths.

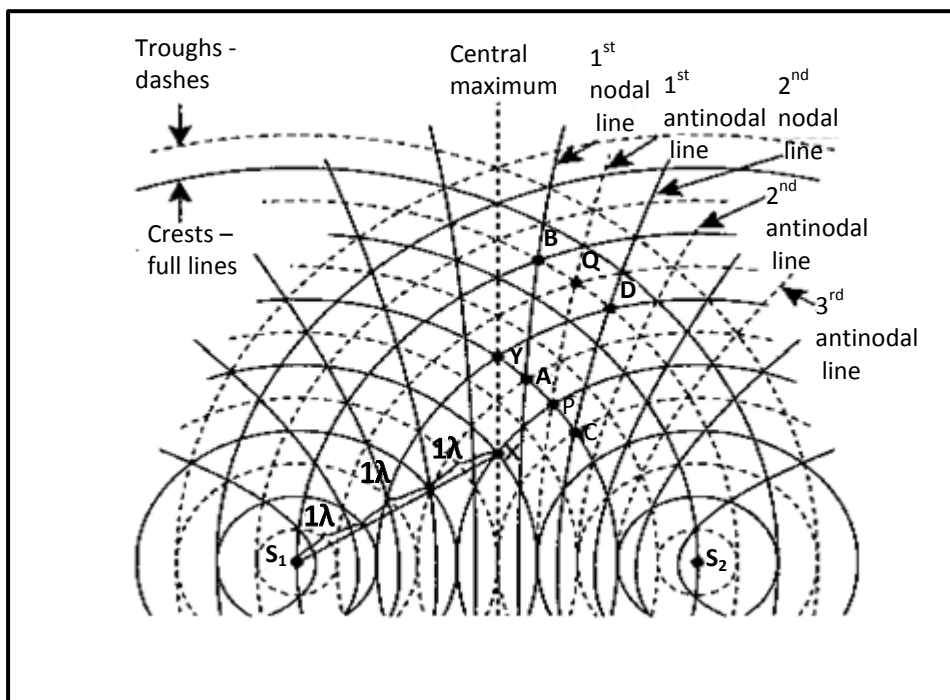

Figure 24: Interference pattern of waves from two sources.

Now look at a point Y further out but still on the central maximum. The difference in distance from the two sources S_1 and S_2 is $S_1Y - S_2Y = 4\lambda - 4\lambda = 0\lambda$. If this is tried again it will be found that the path difference for all points on the central maximum is always zero wavelengths.

Now consider point P on the first antinodal line. The distance from S_1 to P (S_1P) is 4λ and the distance from S_2 to P (S_2P) is 3λ . The path difference is $S_1P - S_2P = 1\lambda$. If we find the path difference for point Q, further out on the first antinodal line, we will again find it to be 1λ . For all points on the first antinodal line the path difference is 1λ .

Interference of light waves

We know that visible light is the type of electromagnetic wave to which our eyes respond. Like all other electromagnetic waves, it obeys the equation $c = f\lambda$ where $c = 3.0 \times 10^8$ m/s is the speed of light in vacuum, f is the frequency of the electromagnetic waves, and λ is its wavelength. The range of visible wavelengths is approximately 380 to 760 nm.

The wave like characteristics of light in interference of light is explained by Thomas Young's double slit experiment.

The wave like characteristics of light in interference of light is explained by Thomas Young's double slit experiment.

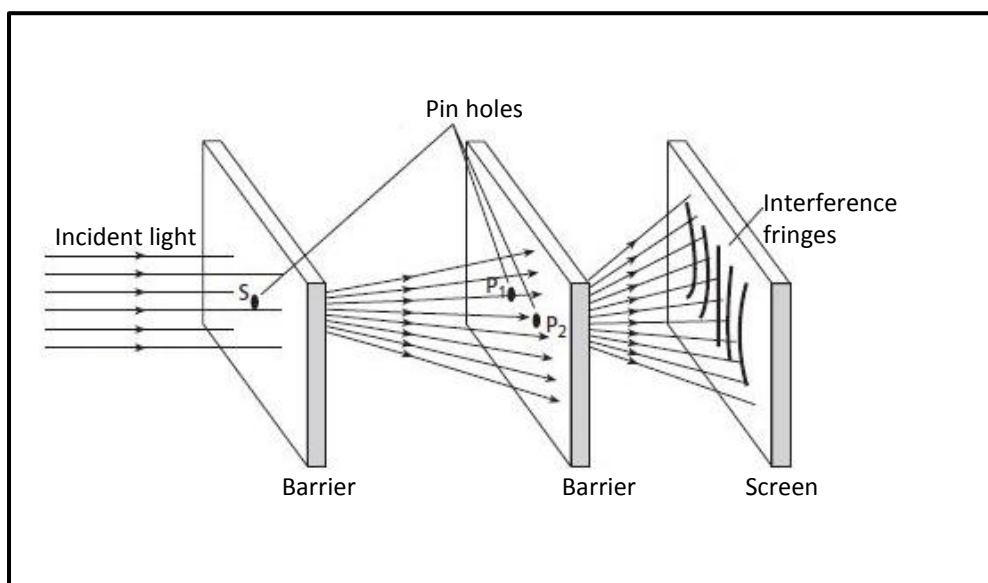

Figure 25: The set-up used by Young to produce interference of light waves.

Light from a source was directed onto an opaque sheet with a single pinhole. Light passed through this hole and was incident on two more pinholes, which were very close together, in another barrier. Light from these two pinholes was incident on a screen placed at a long distance from the barrier. Fringes as shown in figure 26 appeared on the screen. These fringes disappeared when one of the pinholes was covered up this is an indication that the phenomenon was the result of light from the two pinholes interfering.



Figure 26: The interference pattern produced by light incident on a pair of closely spaced slits.

Each pinhole acted like a point source of light, producing circular waves that radiated outward. The intersecting crests and crests, troughs and troughs, produced coloured fringes, and intersecting crests and troughs produced dark fringes. The interference pattern he drew resembled that of water waves. Again, it was Young's unique constructional design of the experiment that allowed these fringes to appear and remain stable — in the one place. Remember, to obtain a stable pattern the sources of the waves have to be continually in phase, which is, producing crests at the same time.

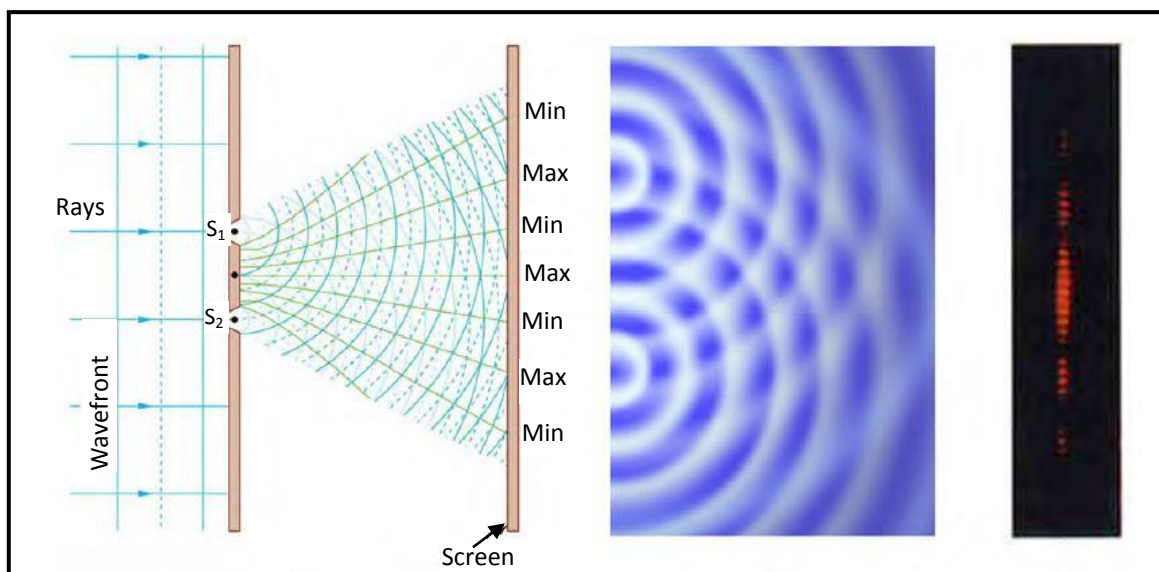
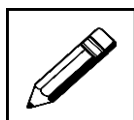

Figure 27: Double slits produce two coherent sources of waves that interfere.

- Light spreads out (diffracts) from each slit, because the slits are narrow. These waves overlap and interfere constructively (bright lines) and destructively (dark regions). We can only see this if the light falls onto a screen and is scattered into our eyes.
- Double slit interference pattern for water waves are nearly identical to that for light. Wave action is greatest in regions of constructive interference and least in regions of destructive interference.
- When light that has passed through double slits falls on a screen, we see a pattern such as this.

Now check what you have just learnt by trying out the learning activity below!



Learning Activity 3



30 minutes

Write your answers in the space provided

- Suppose that there was a ride at an amusement park that was titled The Standing Wave, which location on the ride would give the greatest thrill, node or antinode?
_____.
- A standing wave is formed when
 - a wave refracts due to changes in the properties of the medium.
 - a wave reflects off a canyon wall and is heard shortly after it is formed.
 - red, orange and yellow wavelengths bend around suspended in atmospheric particles.
 - two identical waves moving in different directions along the same medium interfere.



Refer to the diagram below to answer Questions 3 and 4.

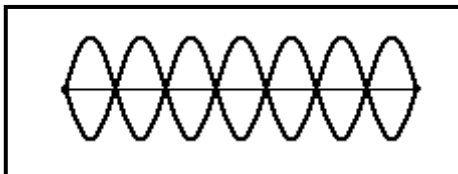

3. The number of nodes in the standing wave shown in the diagram above is _____.
- A. 6 B. 7 C. 8 D. 14
4. The number of antinodes in the standing wave shown in the diagram above is _____.
- A. 6 B. 7 C. 8 D. 14

Refer to the diagram below to answer Questions 5 and 6.

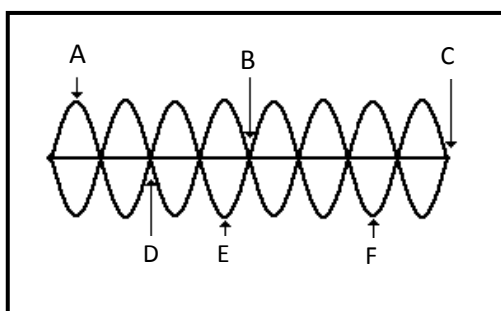

Circle the correct answer.

5. The number of nodes on the pattern is _____.
- A. 7 B. 8
C. 9 D. 16
6. Of all the labeled points, destructive interference occurs at point(s) _____.
- A. B, C and D B. A, E and F
C. A D. E

Thank you for completing learning activity 3. Now check your work. Answers are at the end of the module.



12.3.3 Waves and Boundaries

When waves spread out from a source, they always travel outwards in all directions. But waves encounter different surfaces and different obstacles along their path. At most times waves travel from one medium to another medium. For as long as the medium is the same everywhere, the wave speed and frequency will be constant in all directions. However if there is a change in medium, then some of the properties of the waves will change.

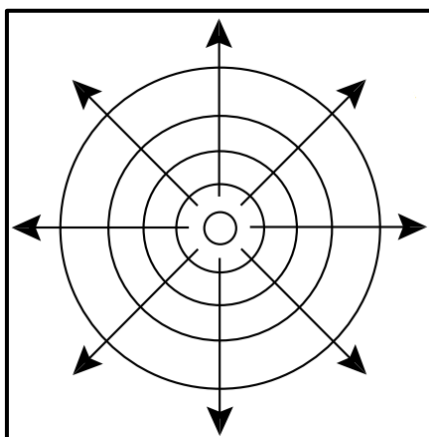

Figure 28: Spreading of waves in all directions.

The speed of a wave is a characteristic of the medium in which it is moving. It changes when a wave moves from one medium to another.

The table below shows examples of wave speed in different media.

Wave Type	Medium	Speed (m/s)
Sound	carbon dioxide	260
	air	331
	hydrogen	1290
	pure water	1410
	salt water	1450
	glass	5500
Light	vacuum	2.997×10^8
	air	2.988×10^8
	glass (crown)	2.0×10^8
Earthquake	crust	3500 (transverse)
		8000 (longitudinal)
	mantle	6500 (transverse)
		11000 (longitudinal)

Table 1: Speed of waves in different media



How can we best explain what happens when a wave hits a barrier or moves from one medium to another? For example, what happens when light hits a mirror?

When waves meet a boundary (one medium to another or an obstacle); the following can occur:

- i. **Reflection:** is the change in direction of propagation of a wave that strikes the boundary of different mediums.
- ii. **Refraction:** the change of speed and direction that occurs when a wave goes from one medium to another.
- iii. **Diffraction:** bending of waves as they pass through narrow openings or around sharp corners.

Propagation of Waves at Boundaries

Reflection

When a plane wave encounters a barrier between two mediums, some or all of it may propagate into the new medium or be reflected from it. The part that enters the new medium is called the **transmitted wave** and the other that bounces off the surface is called the **reflected wave**. Take light for example; most surfaces reflect light in all directions. Very smooth surfaces like mirrors reflect light in a regular manner which results in the formation of images.

In general, light reflected on a rough surface will scatter in all directions and the reflection is described as **irregular** or **diffuse**. Light reflected on a very smooth surface will scatter in geometrical pattern and the reflection is described as **regular**.

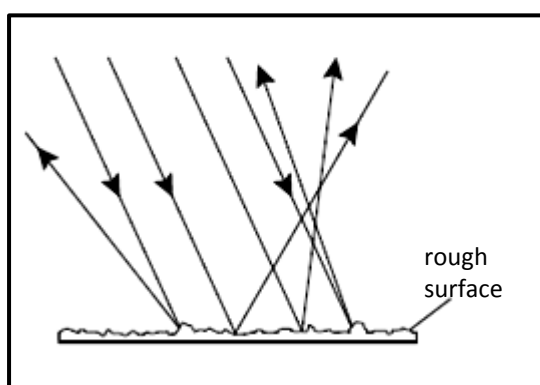

Figure 29a: Irregular (diffuse) reflection

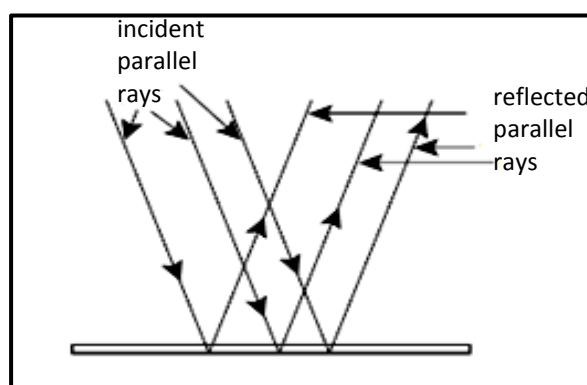

Figure 29b: Regular reflection.

The part of wave which is reflected has a very simple rule governing its behaviour.



The Law of reflection

The fundamental law that governs the reflection of light is called the **law of reflection**. Whether the light is reflecting off a rough, smooth, curved surface or a plane surface, the light ray follows the law of reflection.

The laws of reflection states that when a light ray reflects off a surface:

- 1) The angle of incidence is equal to the angle of reflection.
- 2) The incident ray, the reflected ray and the normal all lie in the same plane.

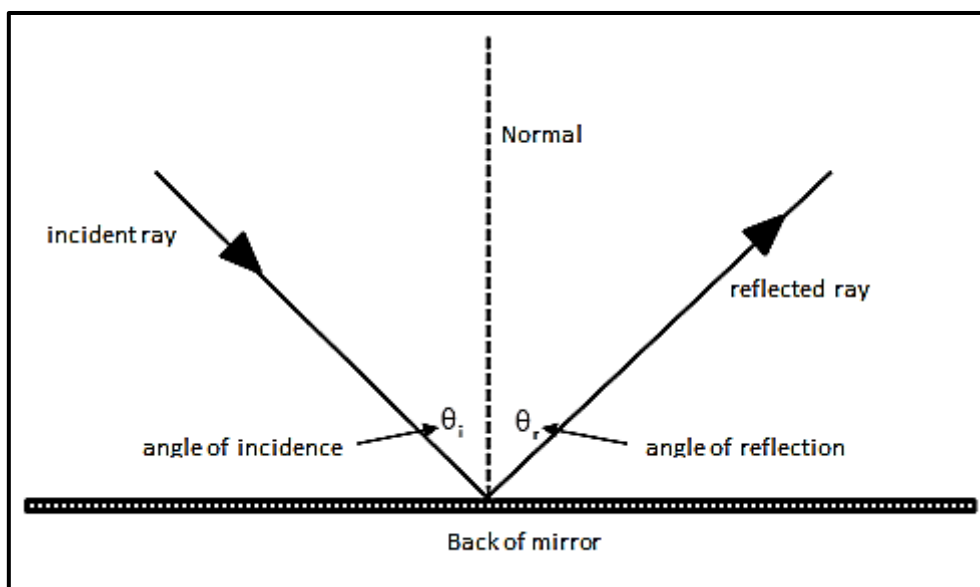

Figure 30: The angle of incidence is equal to the angle of reflection.

The angle of incidence is the angle made by the incident ray with respect to the normal. The angle of reflection is the angle made by the reflected ray with respect to the normal.

Example

A certain ray of light is reflected on a shiny surface. If the incident ray strikes the shiny surface at an angle of 36° with respect to the normal, what is the angle of the reflected ray?

Solution

The angle of incidence is equal to the angle of reflection. Therefore, the angle of reflection is also 36° .



The same principles of reflection apply when circular waves interact with straight barriers or when straight waves reflect from curved barriers, as shown in figure 31a.

Notice for the circular wave in figure 31a that the front part of the wave hits the barrier first, therefore it is reflected first, creating a curved reflected wave that gives the impression that it was made by a source behind the barrier.

Straight waves reflecting from a curved barrier result in the focusing of the waves to a point known as the focal point.

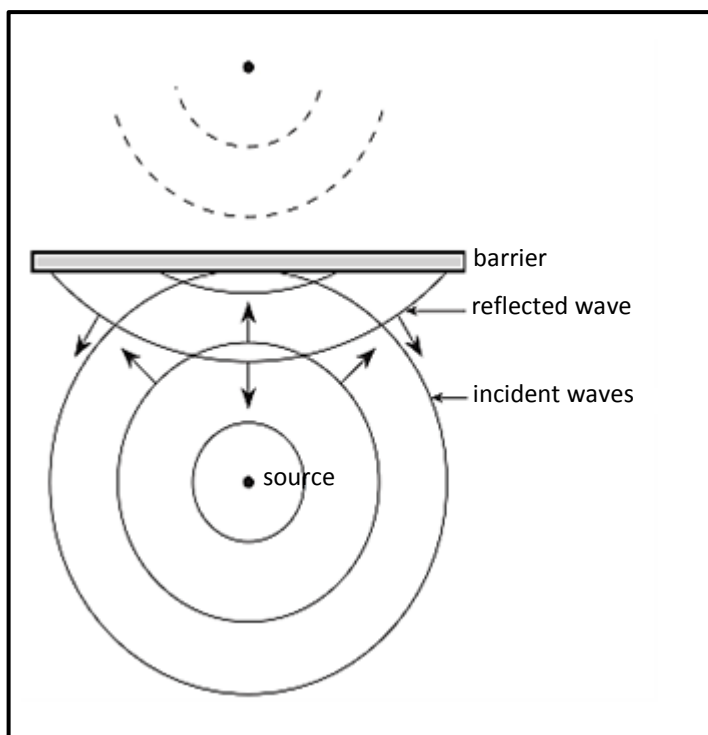

Figure 31a: When a curved wave reflects from straight barrier the reflected wave appears to originate from a point behind the barrier.

After passing through the point where this occurs (the **focal point**) the sides get further behind, resulting in a curved wave. (See Figure 31b)

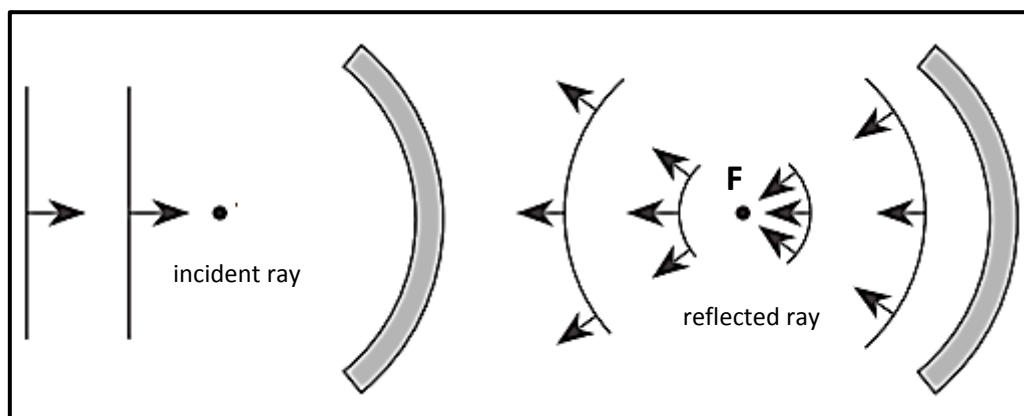

Figure 31b: A straight wave becomes curved and passes through the focal point when reflected from a curved barrier.

Curved waves generated at the focal point (point where waves converge or diverge) and reflecting from the correctly curved barrier can produce straight waves, as shown in Figure 31c on the next page.

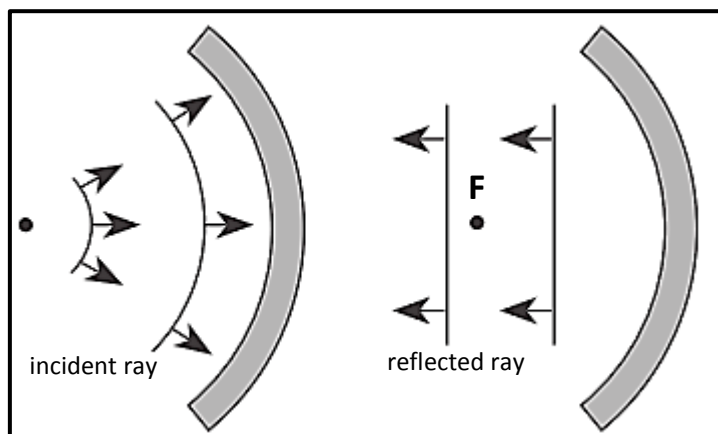
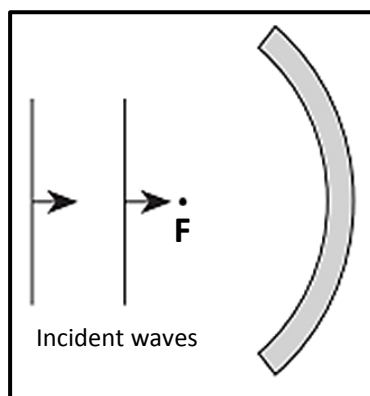

Figure 31c: A wave originating from the focal point of a curved surface is reflected as a straight wave.

Example 3

Draw the reflected wave fronts for the incident wave after reflection from the circular barrier.



Solution

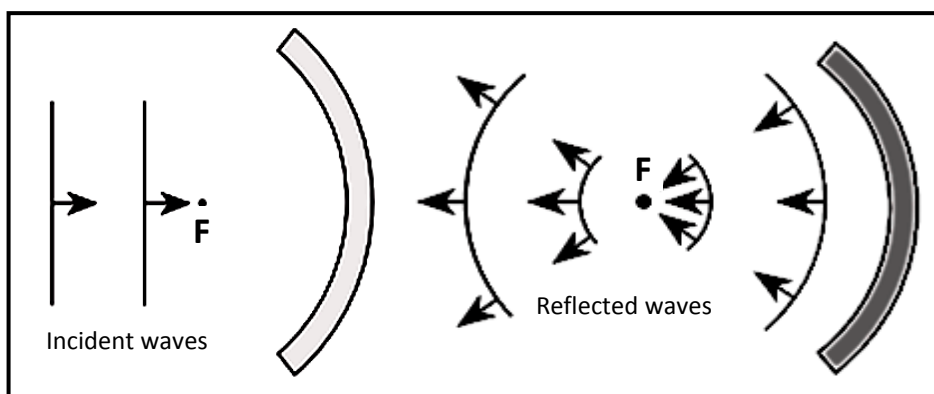

There are many practical examples of the effect of reflection of waves. For instance, the reflection of sound waves allows us to hear echoes. The reflection of light allows us to see images (or objects) and to determine their colours. Moreover, the reflection off smooth surfaces allows light to form images. That is why you are able to see your face in the mirror.

Refraction

Refraction is the change in direction of a wave passing from one medium to another caused by its change in speed. The term **bending** is often used when we mean to say change in direction of a wave.

Refraction of light

Refraction occurs when light moves through two transparent substances of different optical densities. It causes light to change speed and change direction. **Optically dense** indicates the value of the **refractive index** and **NOT** the actual density (mass/volume) of the material.

refractive index				
1.00	1.33	1.49	1.52	2.42
air	water	Perspex	glass	diamond
300	225	201	197	124
(x 1000km/s) speed of light				

increasing refractive index

slower speed

Figure 32: Light travels at different speeds in different transparent substances. These different speeds are the cause of refraction.

Light travels faster in a vacuum, a little slower in gases like air, slower again in liquids like water and slowest in solids like ice, glass, perspex and diamond. The speed of light in a substance depends on the **optical density** or **refractive index** of the substance. Light passing into an optically denser medium is bent towards the normal; light passing into an optically less dense medium is bent away from the normal.

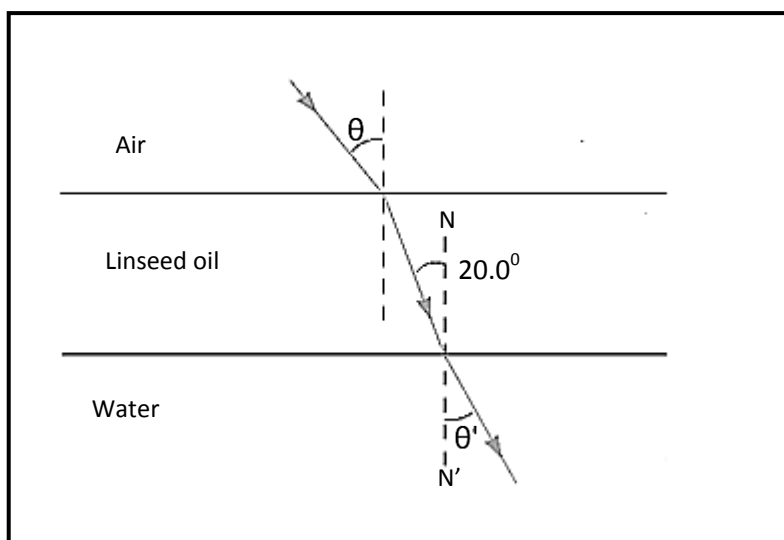

Figure 33: Optical density affects the speed of light.



The Laws of Refraction

Experiments show that there are two laws of refraction:

- (i) The incident and refracted rays are on opposite sides of the normal at the point of incidence, and all three lie in the same plane.
- (ii) The value of $\frac{\sin i}{\sin r}$ is a constant for light passing from one given medium into another. This is known as **Snell's law**.

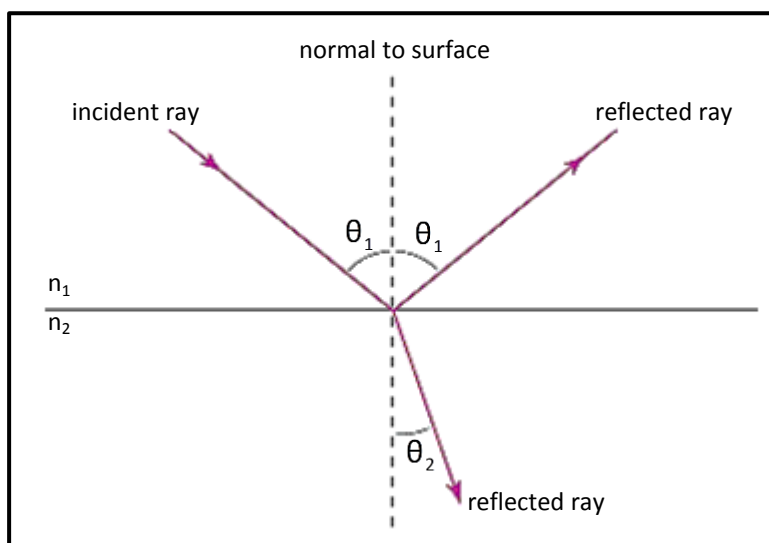

Figure 34: The law of refraction, or Snell's law, predicts the angle at which a light ray will bend, or refract, as it passes from one medium to another.

Snell's law

This law was discovered in 1621 by the Dutch astronomer and mathematician Willebrod Snell (1580–1626). Snell's law states that for any two medium 1 and 2, the ratio of n_1 and n_2 is equal to the ratio of $\sin r$ and $\sin i$

$$\frac{n_1}{n_2} = \frac{\sin r}{\sin i} \rightarrow n_1 \sin i = n_2 \sin r$$

n_1 = refractive index of medium 1

n_2 = refractive index of medium 2

i = angle of incidence

r = angle of refraction

Take note that $\sin i$ and $\sin r$ are often replaced by $\sin \theta_i$ and $\sin \theta_r$, respectively.



The refractive index

The refractive index of a medium gives you an indication of its light-bending ability. For example, light is refracted more by glass than by paraffin, and more by paraffin than water.

$$\text{refractive index}(n) = \frac{\sin i}{\sin r}$$

The greater the refractive index of a medium, the slower is the speed of light. The more light is slowed, the more it is bent.

Substance	Refractive index
water	1.33
paraffin	1.44
Perspex	1.49
glass (soft crown)	1.52
diamond	2.42

Table 2: Refractive indexes of some common (transparent) substances.

Refractive index (n) is a constant derived from the ratio $\frac{\sin i}{\sin r} = n$.
It is known as Snell's law.

Example 1

A ray of light travels between water ($n = 1.33$) and perspex ($n = 1.49$). Find the angle of incidence in water if the angle of refraction in perspex is 20° .

Solution

$$\begin{aligned}n_1 \sin i &= n_2 \sin r \\ \sin i &= \frac{n_2 \sin r}{n_1} \\ &= \frac{1.49 \times \sin 20^\circ}{1.33} \\ &= \sin^{-1}(0.3831654) \\ &= \mathbf{22.5^\circ}\end{aligned}$$

**Example 2**

A ray of light passing from air ($n = 1.00$) is incident on a glass ($n = 1.52$) block at 30° .

- (a) What is the angle of refraction in the glass?
- (b) What is the angle of deviation caused by the glass? Angle of deviation is the angle deviated from the angle of incidence.

Solution

(a)

$$\begin{aligned}n_1 \sin i &= n_2 \sin r \\ \sin r &= \frac{n_1 \sin i}{n_2} \\ &= \frac{1.00 \times \sin 30^\circ}{1.52} \\ &= \sin^{-1}(0.3289474) \\ &= 19.2^\circ\end{aligned}$$

(b)

$$\begin{aligned}\text{Angle of deviation} &= 30^\circ - 19.2^\circ \\ &= 10.8^\circ\end{aligned}$$

Refractive index and speed of light

The relationship between refractive index and the speed of light is given by:

$$\begin{aligned}\text{refractive index} &= \frac{\text{speed of light in vacuum}}{\text{speed of light in medium}} \\ n &= \frac{c}{v}\end{aligned}$$

The **relative refractive index** for light passing from medium 1 to medium 2 is given by the formula:

$$\begin{aligned}\text{relative refractive index} &= \frac{\text{refractive index of medium 2}}{\text{refractive index of medium 1}} \\ \text{relative refractive index} &= \frac{n_2}{n_1}\end{aligned}$$

**Example 3**

If the refractive index of water is four thirds ($4/3$), what is the speed of light in water?

Solution

$$n = \frac{c}{c'}$$
$$c' = \frac{c}{n}$$
$$= \frac{300000 \text{ kms}^{-1} \times 3}{4}$$
$$= \mathbf{225000 \text{ kms}^{-1}}$$

Example 4

Calculate the refractive index of the material in the diagram below.

Solution

$$\text{refractive index}(n) = \frac{\sin i}{\sin r}$$
$$= \frac{\sin 65^\circ}{\sin 30^\circ}$$
$$= \mathbf{1.81}$$

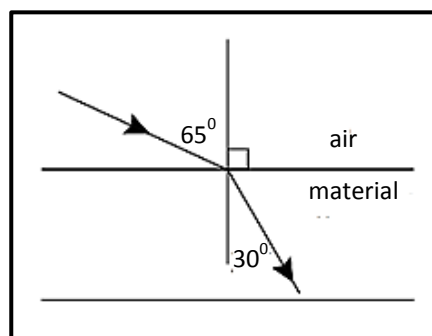
**Example 5**

A drop of soapy water ($n = 1.38$) was placed onto a block of glass ($n = 1.5$), as shown in the diagram below.

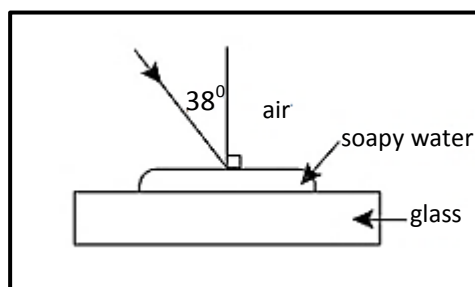

A ray from a laser was shone onto the water at an angle of 38° . Calculate the:

- angle of refraction in the soapy water;
- angle of refraction in the glass;
- angle at which the ray exited from the glass;
- the relative refractive index of light going from soapy water to glass.

**Solution**

(a)

$$\begin{aligned} \sin r &= \frac{n_1 \sin i}{n_2} \\ &= \frac{1.00 \times \sin 38^\circ}{1.38} \\ &= 0.44613150 \\ &= \sin^{-1}(0.44613150) \\ &= \mathbf{26.5^\circ} \end{aligned}$$

(b)

$$\begin{aligned} \sin r &= \frac{n_1 \sin i}{n_2} \\ &= \frac{1.38 \times \sin 26.5^\circ}{1.5} \\ &= 0.41050199 \\ &= \sin^{-1}(0.41050199) \\ &= \mathbf{24.2^\circ} \end{aligned}$$

(c)

$$\begin{aligned} \sin r &= \frac{n_1 \sin i}{n_2} \\ &= \frac{1.5 \times \sin 24.2^\circ}{1.00} \\ &= 0.61488456 \\ &= \sin^{-1}(0.61488456) \\ &= \mathbf{37.9^\circ} \end{aligned}$$

(d)

$$\begin{aligned} \text{relative refractive index} &= \frac{n_2}{n_1} \\ &= \frac{1.5}{1.38} \\ &= \mathbf{1.09} \end{aligned}$$

Refraction of water waves

Refraction of water waves is influenced by the depth of water. Water waves travel more slowly in shallow water than in deep water. As water waves move from shallow to deep or deep to shallow region, the frequency remains constant because the waves are produced by one source. But the wavelength will change as well as the speed.

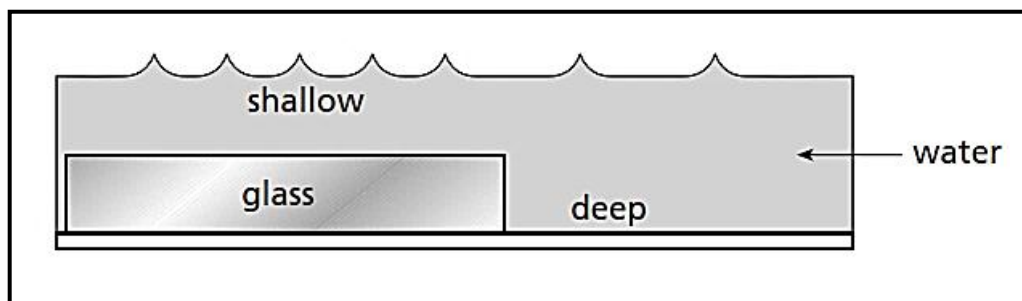

Figure 35: Illustration of refraction of water waves. Depth of water causes refraction in water waves.

Depth	Wavelength	Speed	Frequency
Shallow	Short	Slow	Same
Deep	Long	Fast	Same

Table 3: Changes in wave characteristics during refraction of water waves.

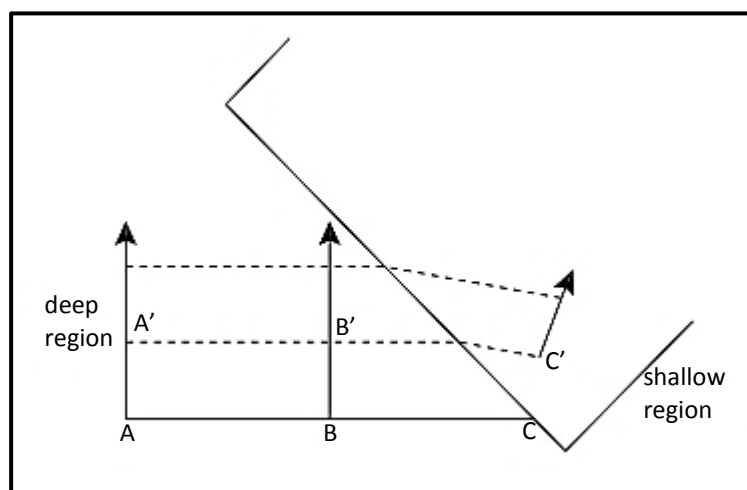

Figure 36: When a wave hits the boundary between two depths of water at an angle, it changes direction.

Example 1

Straight waves of wavelength 2.5cm have a speed of 8cm s^{-1} in a region in a ripple tank where the depth of water is 2cm. They pass into a region of depth 1cm where the speed is determined to be 6cm s^{-1} .

Find the wavelength of the waves in the new region.

**Solution**

The wave equation, $v = f\lambda$ is used to find the wavelength in the new region. But from the information given, frequency of the waves in the new region is not known.

Therefore, we have to calculate the frequency by using the parameters of the waves in the deep region.

$$\begin{aligned}f &= \frac{v}{\lambda} \\ &= \frac{8\text{cm s}^{-1}}{2\text{cm}} \\ &= 3.2\text{s}^{-1} \\ &= \mathbf{3.2\text{Hz}}\end{aligned}$$

The frequency of the waves is constant in the ripple tank because there is only one source. Therefore, the wavelength is:

$$\begin{aligned}\lambda &= \frac{v}{f} \\ &= \frac{6\text{cm s}^{-1}}{3.2\text{s}^{-1}} \\ &= \mathbf{1.9\text{cm}}\end{aligned}$$

The wavelength of the waves in the new region is **1.9cm**

Example 2

The diagram below indicates the position of straight waves in a ripple tank at a particular instant. The velocity of the waves in section A is 10cm s^{-1} .

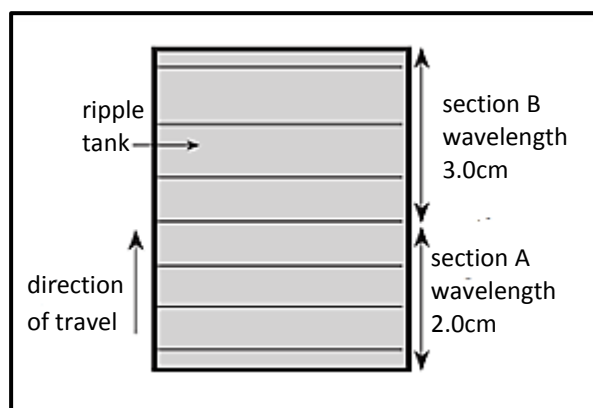

- Explain the reason for the different wavelengths in the two sections.
- Calculate the frequency of the waves in section A.
- What is the frequency of the waves in section B?
- What is the speed of the waves in section B?

Solution

(a) There are two different wavelengths in the ripple tank because the depth of the ripple tank is not constant. The depth at section B is deeper than in section A that is why the wavelength at section B is longer than in section A.

(b)

$$\begin{aligned} f &= \frac{v}{\lambda} \\ &= \frac{10\text{cms}^{-1}}{2\text{cm}} \\ &= \mathbf{5\text{Hz}} \end{aligned}$$

(c) There is only one source in the ripple tank so the frequency at section B is **5Hz**.

(d)

$$\begin{aligned} v &= f\lambda \\ &= 5\text{s}^{-1} \times 3\text{cm} \\ &= \mathbf{15\text{cms}^{-1}} \end{aligned}$$

Diffraction

Diffraction is the bending of waves as they pass through an opening (gap) or around the edge of an object in their path. This bending of waves is more noticeable if the wavelength of the waves is comparable to the size of the opening.

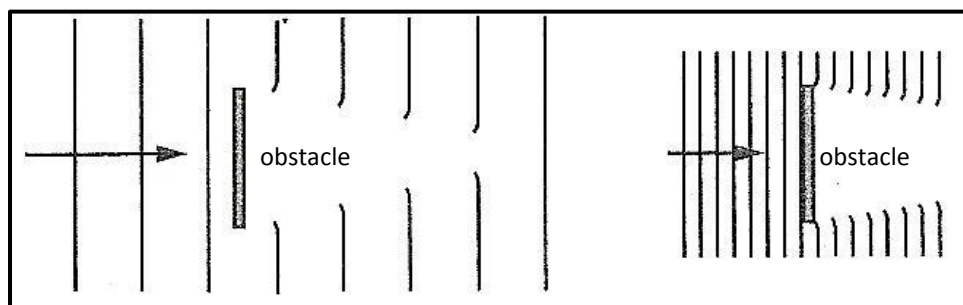

Figure 37a: Diffraction around obstacles. The wavelength does not change.

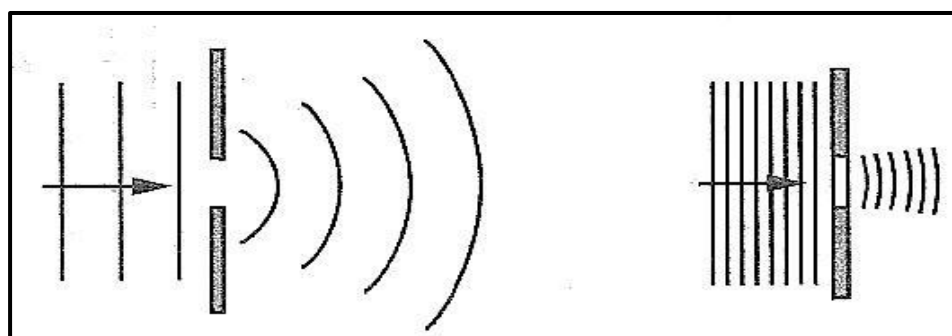

Figure 37b: Diffraction through gaps (holes). The wavelength does not change.



- Less diffraction occurs if the wavelength is smaller when they pass around an obstacle.
- Less diffraction occurs if the wavelength is smaller when they go through a larger gap (or opening)

Also, if an object is in the path of the travelling waves, a **shadow** is produced if the object is of the same size as the wavelength.

Water waves can be used to study how diffraction occurs. A diffraction pattern can be observed in the ocean around boats, large rocks and buoys. However, the amount of diffraction depends on the size of the objects compared with the wavelength. If the object is large compared with the wavelength a significant diffraction pattern occurs around the edges of the object, producing a shadow zone.

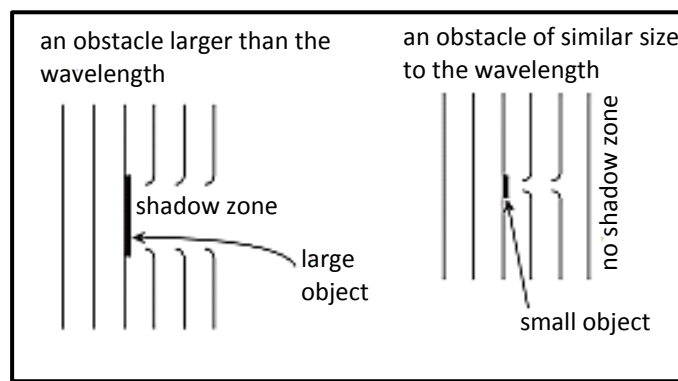

Figure 38: An obstacle affects the waves if it is large compared with the wavelength of the waves, producing a shadow zone.

Let us look at the following diagrams which show the different wave patterns of diffraction.

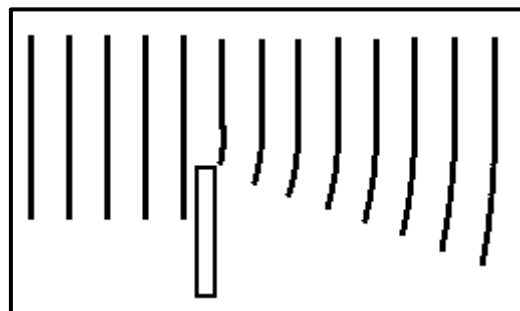

Figure 39: Shorter wavelength around the edge of an obstacle produces small diffraction effect.

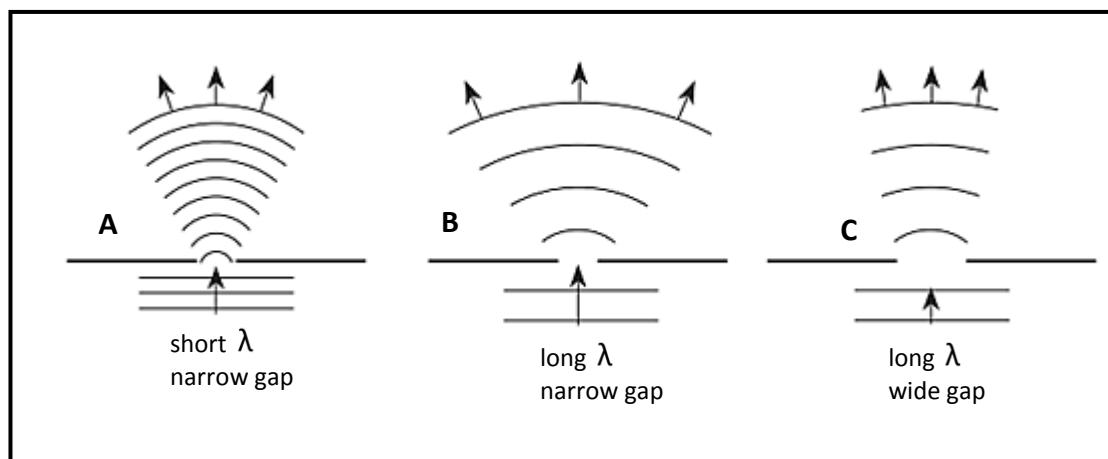

Figure 40: Diffraction is greater when the wavelength is large and the gap narrow.

- A:** Narrow gap and short wavelength produces large diffraction effect.
- B:** Narrow gap and long wavelength produces large diffraction effect.
- C:** Wide gap and long wavelength produces small diffraction effect.

The diagrams show that the diffraction effects are greater for:

- (a) long wavelength waves
- (b) for small holes

The next diagram shows a wave bending round the edge of a barrier. This explains why it is possible to hear sounds and receive radio signals even if there is something between you and the source of the waves.

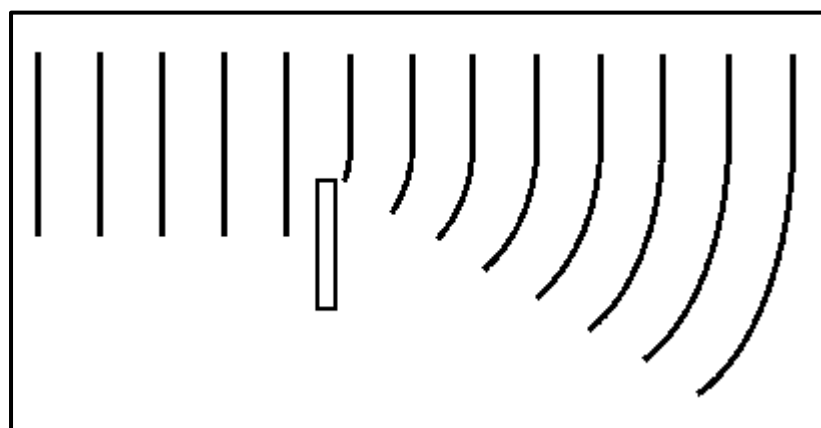

Figure 41: Diffraction wave pattern around the edge of a barrier.

If the wavelength of the waves is shorter the spreading, diffraction, effect is much smaller as well. This explains why television waves are much more difficult to receive in hilly areas than radio waves which have a longer wavelength and why the diffraction of light is so difficult to observe.

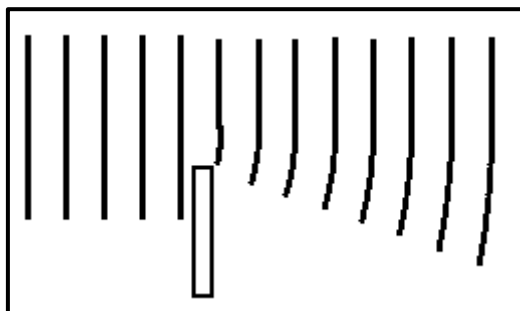

Figure 42: Shorter wavelength around the edge of an obstacle produces small diffraction effect.

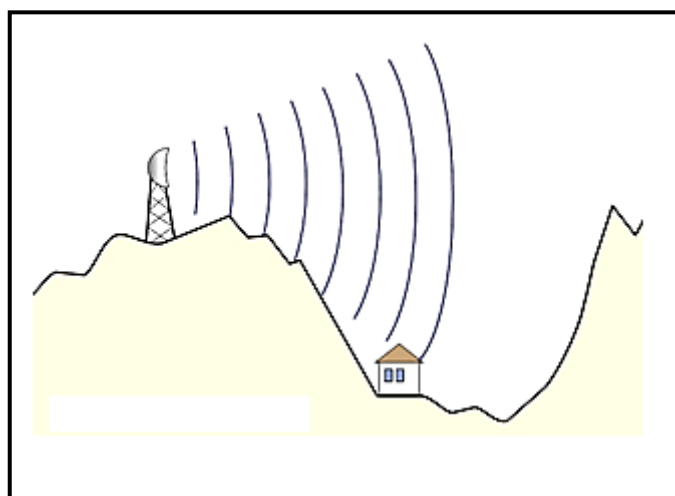

Figure 43: Radio reception in a hilly area

Some examples of the effect of diffraction include:

- blurry shadows
- blurry TV screens
- hearing a sound at a corner of a room
- when sound of various wavelengths or frequencies is emitted from a loudspeaker, the loudspeaker itself acts as an obstacle and casts a shadow to its rear so that only the longer bass notes are diffracted there
- when a beam of light falls on the edge of an object, it will not continue in a straight line but will be slightly bent by the contact, causing a blur at the edge of the shadow of the object
- diffraction of water waves in the ocean is partly responsible for the formation of many offshore islands

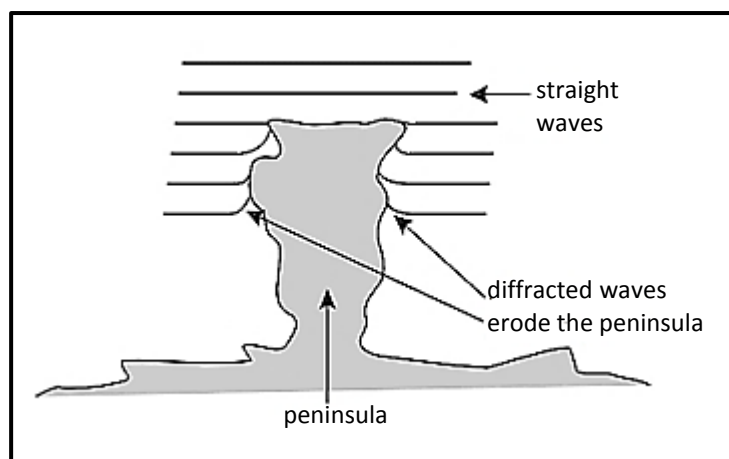

Figure 44: Straight waves in the ocean diffract around a peninsula, causing erosion on the sides, eventually cutting off the peninsula.

Example 1

How is it possible that you can still hear someone talking on the street while you are in your room studying?

Solution

You do not have to be in line with the open window or on the street in order to hear the person talking because of the effect of diffraction. Sound waves travel to your ears by bending around the edge of the windows to your ears.

Example 2

Explain with the use of diagrams the meaning of diffraction.

Solution

Diffraction is the bending of a wave around the edges of an obstacle or opening (or gaps) on an obstacle (or barrier).

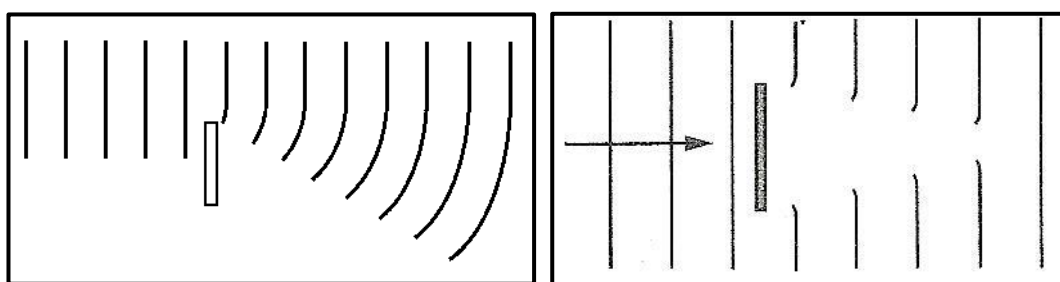

Figure 45: Diffraction around obstacles

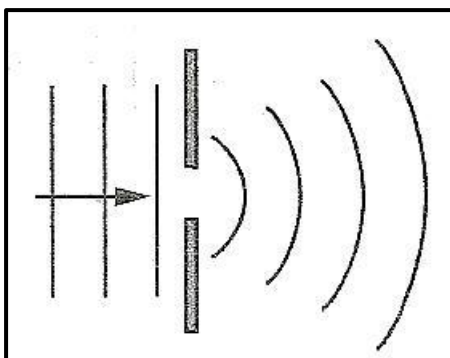
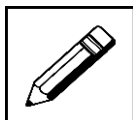

Figure 46: Diffraction around the edge of an opening (or gap)

Now check what you have just learnt by trying out the learning activity below!



Learning Activity 4



50 minutes

Read and answer the following questions accordingly in the space provided.

1. State the two ideas that explain the law of reflection.

- (i) _____

- (ii) _____

2. If the angle of reflection from a shiny plane surface is 55° , what is the angle of the incident light ray when it strikes the shiny surface? _____.

3. Explain the following terms.

- (i) Diffuse reflection

- (ii) Regular reflection



4. Study the diagram below and draw the resulting reflected waves in the empty box on the right.

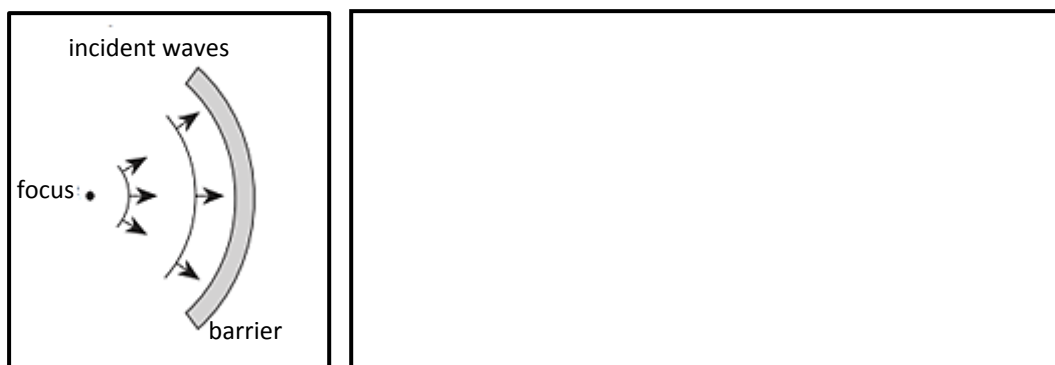

5. The speed of light in empty space (vacuum) is $3 \times 10^8 \text{ ms}^{-1}$ but in glass light slows to $2 \times 10^8 \text{ ms}^{-1}$. What is the refractive index of glass?

6. What is the speed of light in a medium of refractive index 1.2 if its speed in air is $3 \times 10^8 \text{ ms}^{-1}$?

7. For the diagram on the right, find n_2 .

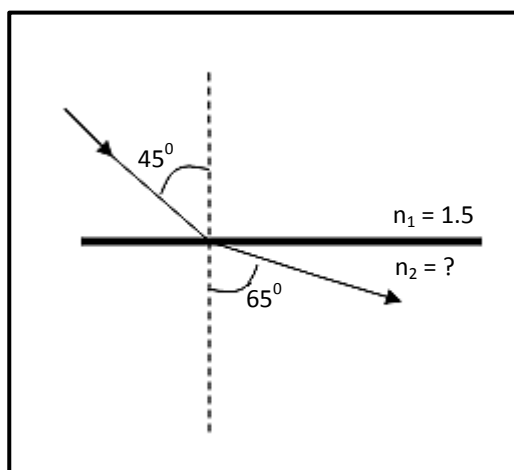



8. A ray of light exits from a material with $n = 1.80$, traveling into air. The angle of refraction is 20° .
- a) What is the speed of light in this material?
- b) What was the original angle of incidence?
- c) What is the angle of deviation?

9. For the drawings below, state whether $n_1 > n_2$, $n_1 < n_2$, or $n_1 = n_2$.

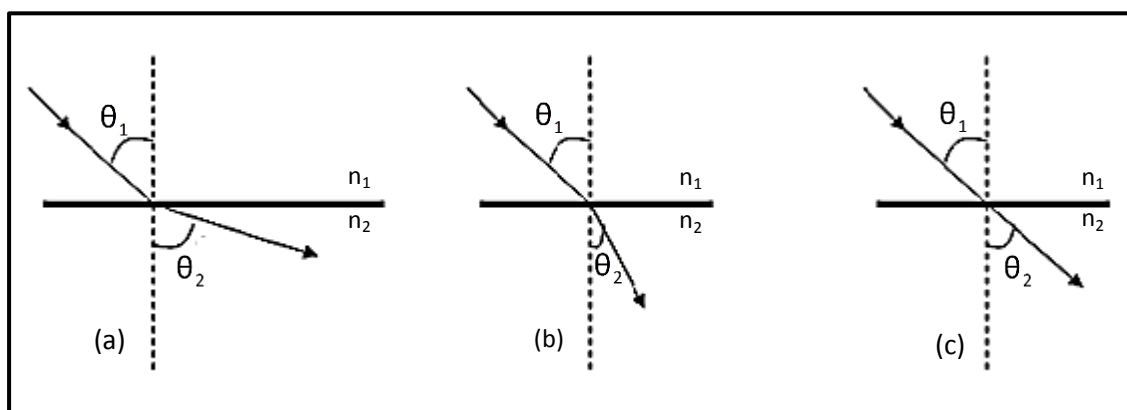

- (a) _____.
- (b) _____.
- (c) _____.



10. Straight waves of wavelength 3.5cm have a speed of 7.5cm s^{-1} in a region in a ripple tank where the depth of water is 2cm. They pass into a region of depth 1cm where the speed is determined to be 5.5cm s^{-1} .

Find the wavelength of the waves in the new region.

11. Study the two diagrams below and complete the diagrams by drawing the diffracted wave patterns when the waves pass through the barriers.

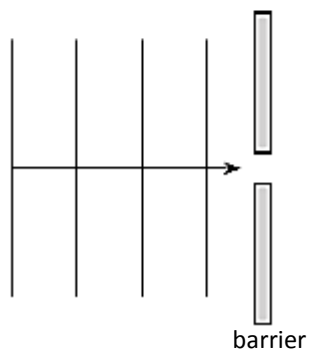
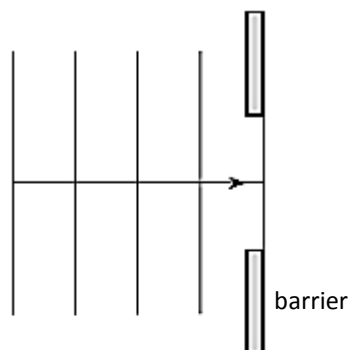



12. Show with the use of diagrams how the diffraction pattern depends on the size of the opening and the size of the wavelength of the waves.

Thank you for completing learning activity 4. Now check your work. Answers are at the end of the module.

12.3.4. Applications

There are many applications of the use of the wave properties. Examples of such applications are found in the use of mirrors and lenses, sonar technology, optical fibres or periscopes, study of spectroscopy, audio systems and crystal analysis.

As there are many applications of reflection, refraction and diffraction, this section will only focus on the applications involving:

- i. light waves
- ii. sound waves

Applications Involving Light Waves

We will focus on two practical applications involving light waves. They are total internal reflection and the effect of refraction of light waves

Total internal reflection

When light travels from a more optically dense substance (glass) into a less optically dense one (air), it sometimes reflects instead. If the incident ray makes an angle of refraction of 90° , there would be a total **internal reflection**. The angle of incidence that produces a refraction angle of 90° is called the **critical angle**.

For total internal reflection to occur, light must travel from a substance of high optical density into a substance of low optical density. It must strike at an angle greater than the critical angle of incidence.

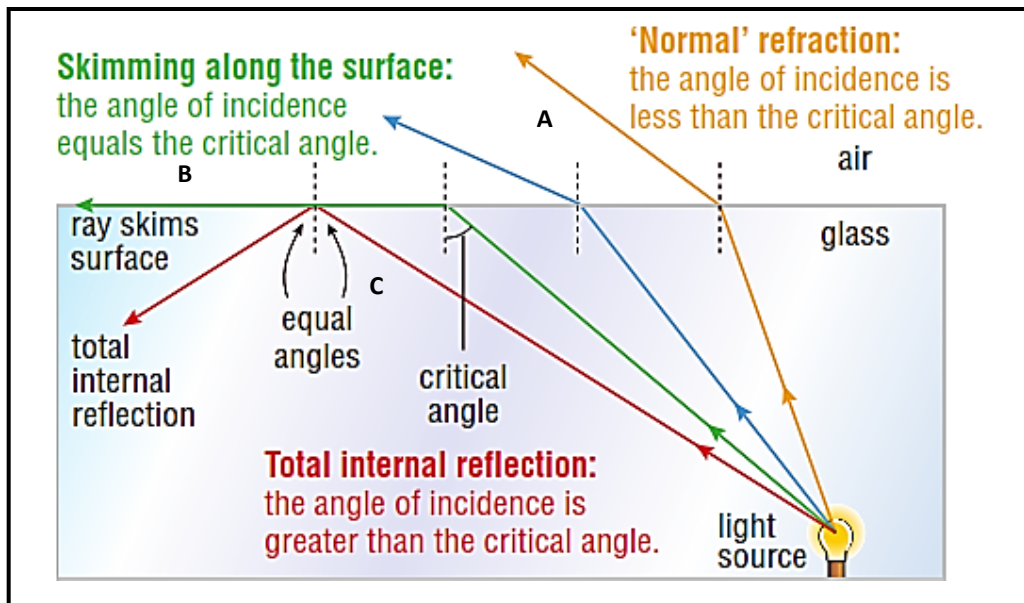

Figure 47: Ray B Ray-at the boundary Ray C-total internal reflection

The relationship between the critical angle of incidence and refractive index is given by the following equations:

General formula

$$\frac{n_1}{n_2} = \frac{\sin 90^\circ}{\sin c}$$

$$\sin c = \frac{n_2 \sin 90^\circ}{n_1}$$

$$= \frac{n_2}{n_1}$$

For light passing through any medium into air (or vacuum)

$$\text{refractive index } (n) = \frac{\sin i}{\sin r} = \frac{\sin 90^\circ}{\sin c} = \frac{1}{\sin c}$$

$$\sin c = \frac{1}{n}$$

$$\sin c = \text{critical angle of incidence}$$

**Example 1**

A transparent material has a refractive index of 2. Calculate the value of the critical angle.

Solution

$$\begin{aligned}\sin c &= \frac{1}{n} \\ &= \frac{1}{2} \\ &= 0.5 \\ &= \sin^{-1}(0.5) \\ &= \mathbf{30^\circ}\end{aligned}$$

Example 2

The refractive index for glass is 1.52 and for air is 1.00. What is the critical angle for light passing from glass to air?

Solution

$$\begin{aligned}\sin c &= \frac{n_2 \sin 90^\circ}{n_1} \\ &= \frac{1.00 \times \sin 90^\circ}{1.52} \\ &= \frac{1.00}{1.52} \\ &= 0.65789 \\ &= \sin^{-1}(0.65789) \\ &= \mathbf{41.1^\circ}\end{aligned}$$

Example 3

The critical angle for light passing from a clear substance into air is 40.5° . Calculate the index of refraction for the substance.

Solution

$$\begin{aligned}\sin c &= \frac{1}{n} \\ n &= \frac{1}{\sin c} \\ &= \frac{1}{\sin 40.5^\circ} \\ &= \mathbf{1.54}\end{aligned}$$

Uses of total internal reflection

(i) Prisms in periscope

A glass $45^\circ/45^\circ$ prism as shown in figure 48a can be used for total internal reflection and has many uses. Light striking one surface of the prism at right angles makes an angle of 45° with the second surface. The angle of incidence is greater than the critical angle of 42° and the light is therefore reflected from this surface. It then strikes the third surface at right angles. The rays have thus made right-angled turns. This makes them useful in quality periscopes (figure 48b). They have an advantage over mirrors because mirrors produce multiple images as light is reflected from the back and front.

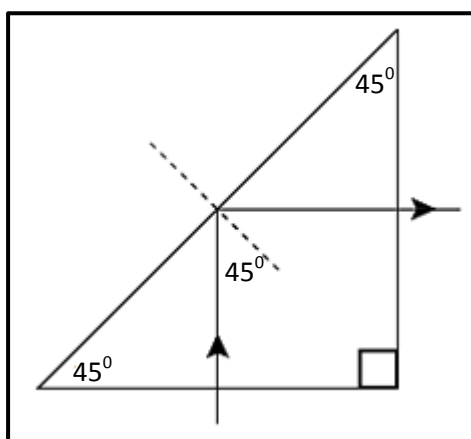

Figure 48a: Because of total internal reflection prisms are capable of bending light rays through 90°

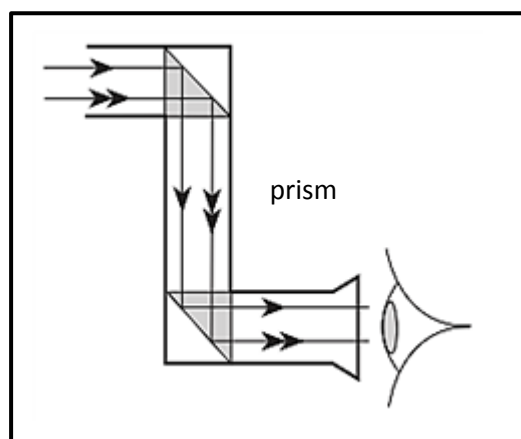

Figure 48b: Periscopes use total internal reflection in prisms.

(ii) Optical fibres

Optical fibres use total internal reflection to trap light within a thin, flexible strand. An optical fibre consists of a very pure glass fibre as thin as a hair 0.125mm with a layer of cladding around the outside, to protect it from damage and moisture. The outside layer has a lower refractive index than the inside material, thus creating a situation where light propagating in the central layer is travelling in a more dense material than in the outside layer. This means the light is totally internally reflected if it strikes the boundary between the two media at an angle greater than the critical angle. Thus light is reflected internally along the length of the fibre.

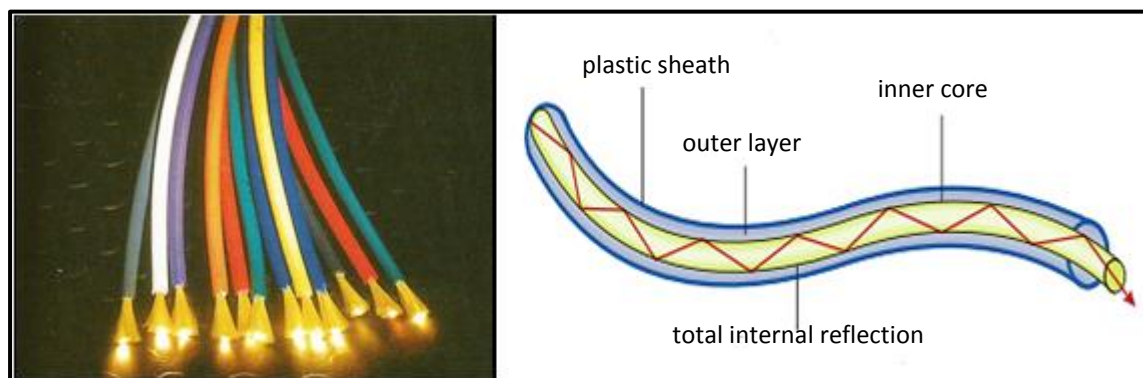

Figure 49: An optical fibre consists of a thin glass fibre of higher refractive index than the outside cladding layer. Thus, total internal reflection is used to reflect light pulses along the length of the fibre.

Apart from communication technology, optical fibres are used in endoscopes. These flexible instruments contain optical fibres and can be passed via the mouth into the lower parts of the digestive system to provide doctors with images (magnified around four times) of the stomach and intestinal lining.

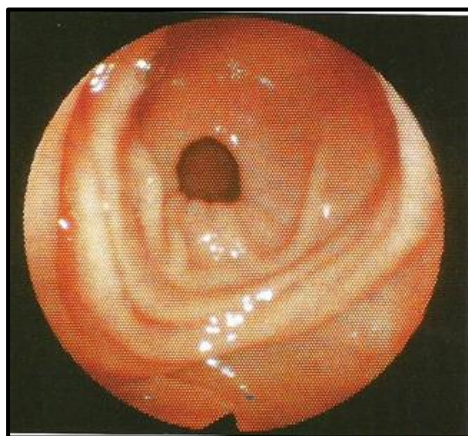

Figure 50: An endoscope showing the internal digestive tract.

Effect of refraction

The effect of refraction involving light waves that we are going to look at is **real and apparent depths**.

Light rays from an object in water or under a flat sheet of glass, appear to be **shallow** than they are. This is because light rays bend away from the normal. The bending of light can give you a false impression of depth.

The real depth and apparent depth are related to refractive index by the following equation:

$$\text{refractive index} = \frac{\text{real depth}}{\text{apparent depth}}$$

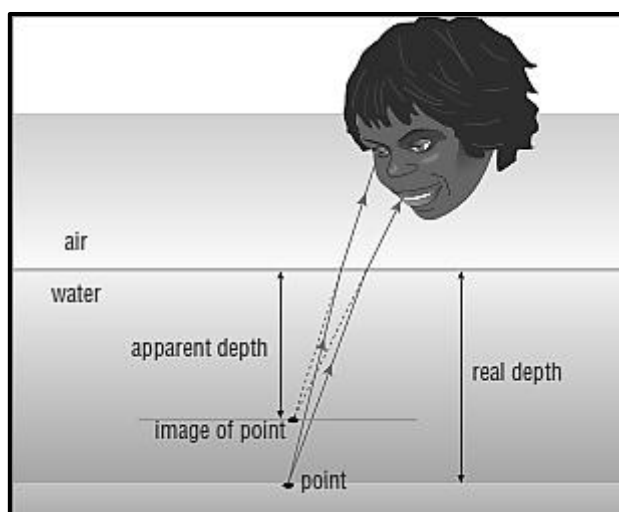

Figure 51: Refraction makes it difficult to judge depth.

**Example 1**

A glass block appears to be 6cm thick when viewed from above. If the refractive index of the glass is 1.5, what is the actual thickness of the block?

$$\begin{aligned}\text{real depth} &= n \times \text{apparent depth} \\ &= 1.5 \times 6\text{cm} \\ &= \mathbf{9\text{cm}}\end{aligned}$$

Example 2

A stone at the bottom of a pool ($n = 1.33$) in a creek appears to be 1.2m from the surface. What is the true depth of the pool?

$$\begin{aligned}\text{real depth} &= n \times \text{apparent depth} \\ &= 1.33 \times 1.2\text{m} \\ &= \mathbf{1.6\text{m}}\end{aligned}$$

Example 3

A liquid is 25cm deep and has a refractive index of 1.25.

- What is its apparent depth when viewed from above?
- What is the critical angle for the liquid?

Solution

a)

$$\begin{aligned}\text{apparent depth} &= \frac{25\text{cm}}{1.25} \\ &= \mathbf{20\text{cm}}\end{aligned}$$

b)

$$\begin{aligned}\sin c &= \frac{1}{1.25} \\ &= 0.8 \\ &= \sin^{-1}(0.8) \\ &= \mathbf{53.1^\circ}\end{aligned}$$



Applications Involving Sound Waves

We will focus on the application principle of echoes. An echo is basically reflected sound waves. Hard surfaces like walls reflect sound waves. When sound waves are reflected, you will hear the reflected sound waves a short time after the original sound.

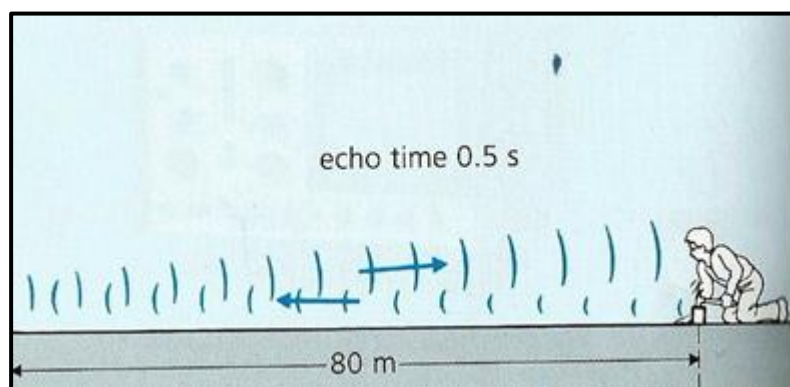

Figure 52: A person creating an echo.

The person in figure 52 is 80 metres from a large brick wall. He is hammering a block of wood. Every time he hits the block, he hears an echo 0.5 seconds later. This is called the **echo time**.

This information can be used to calculate the speed of sound.

$$\begin{aligned} \text{speed of sound} &= \frac{\text{distance travelled}}{\text{time taken}} \\ &= \frac{\text{distance to wall and back}}{\text{echo time}} \\ &= \frac{80\text{m} \times 2}{0.5\text{s}} \\ &= 320\text{ms}^{-1} \end{aligned}$$

This principle is used in the reflection of ultrasounds. Ultrasounds are very high frequency sound waves which can be produced as highly directional beams.

The human ear can detect sounds up to a frequency of about 20000Hz. Ultrasounds are above the range of human hearing. To produce ultrasound, oscillations from electronic circuits can be used to make a crystal vibrate at high frequency.

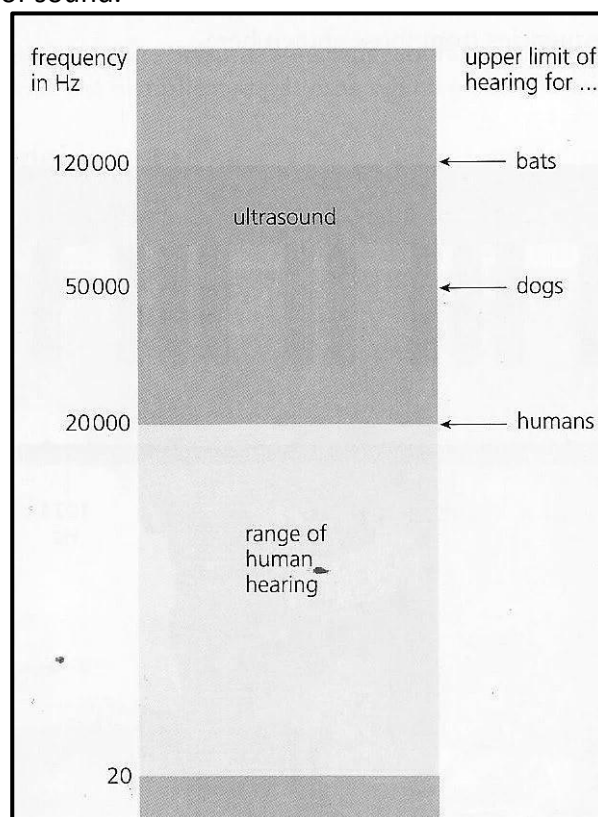

Figure 53: Ultrasound frequency of different animals



Naturally, animals like the bat, especially uses ultrasound to find food and other things or navigate. It sends out ultrasound pulses and uses its specialized ears to pick up reflections.

There are many practical situations where the reflection of ultrasound is very useful. The following are some examples.

Cleaning and breaking

Delicate machines can be cleaned without dismantling them. They are put into a tank of liquid where vibrations of high power ultrasound are used to dislodge the dirt and grease.

Hospitals use concentrated beams of ultrasound to break kidney stones and gall stones without patients undergoing surgery.

Sonar (sound navigation and ranging)

Sonar has many maritime applications such as depth sounding and the location of fish or submerged objects. It sends pulses of sound waves towards the sea bed and measures the echo time. The longer the time, the deeper the water. The time taken for a short pulse to be reflected back can be used to calculate the distance to the reflecting surface.

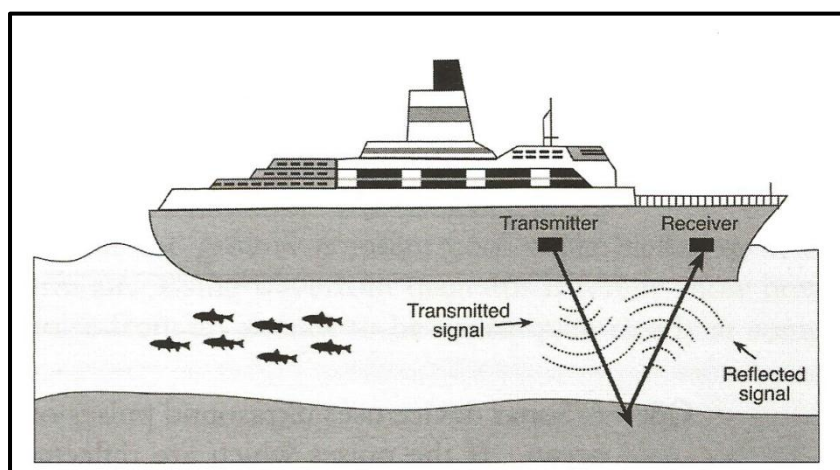

Figure 54: Using sonar to locate fish and ocean floor.

Medical use of ultrasound

In medicine, ultrasound waves are used by doctors to obtain images of internal parts of the body. Ultrasound wave pulses are sent by a transmitter which picks up the reflected pulses from the internal layers. The signals are processed by a computer which displays the image on the screen. Ultrasound can also be used to check the growth of unborn babies and also monitor their heart beat. The movement of the heart changes the frequency of reflected ultrasound.

Using ultrasound to analyze the development of an unborn baby is safer than using X-rays because X-rays can cause cell damage in a growing baby. X-rays do not show clear image of soft tissues.

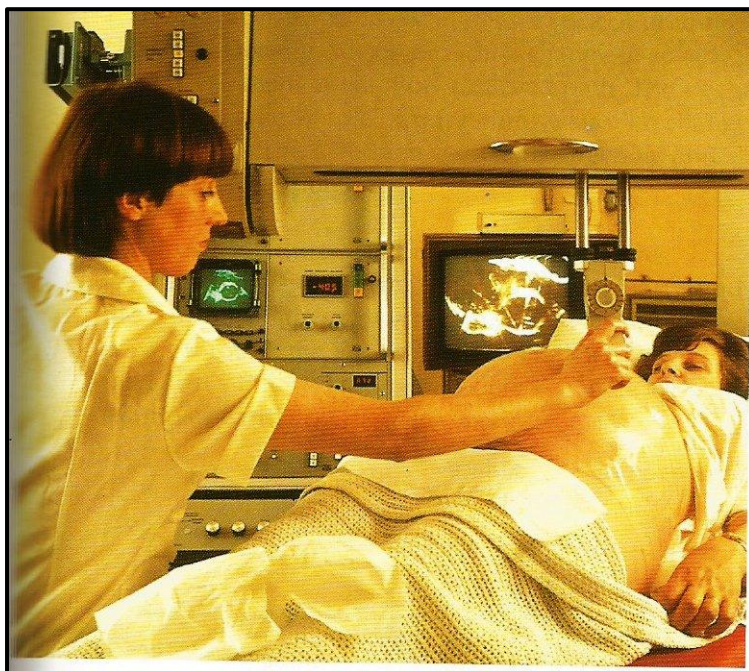

Figure 55: A nurse scanning a pregnant mother using ultrasound.

Example

The echo sounder (sonar) in a ship sends a burst of sound waves towards the seabed. The ship picked up the reflected waves after 0.1 seconds.

- How long did it take the waves to reach the seabed?
- If the speed of sound in water is 1400ms^{-1} , how far is it to the seabed?

Solution

- The echo time is 0.1 seconds. That means it took the waves **0.05 seconds** to reach the seabed.

- distance travelled = speed \times time
 $= 1400\text{ms}^{-1} \times 0.1\text{s}$
 $= 140\text{m}$

However, the sound has to travel down and back. Therefore, the depth is **70m**.

Now check what you have just learnt by trying out the learning activity on the next page!

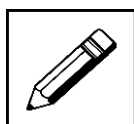

Learning Activity 5



50 minutes

Answer the following questions on the spaces provided.

1. State the two conditions required for total internal reflection to occur.

(i) _____

(ii) _____

2. Explain why a glass ($45^\circ/45^\circ$) prism is preferred over a mirror in the production of periscopes.

Refer to the diagram below to answer Questions 3.

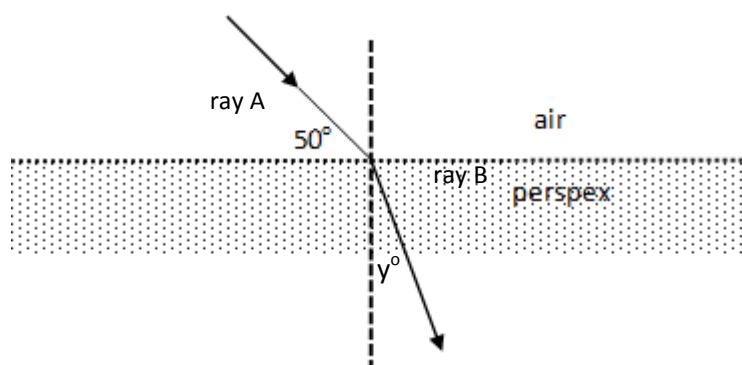

3. a) What are rays A and B respectively?
Ray A _____
Ray B _____
- b) Calculate the angle of incidence.



- c) The refractive index of perspex is 1.49. Calculate the angle of refraction (γ°).
- d) If the speed of light in air is $3 \times 10^8 \text{ ms}^{-1}$ what is the speed of light in perspex?
- e) What is the critical angle of perspex?
-

4. What is the critical angle for light passing from glass ($n = 1.52$) to perspex ($n = 1.49$)?
-

5. The critical angle for light passing from a transparent substance into air is 50.5° . Calculate the index of refraction for the substance.
-



6. A glass block appears to be 8cm thick when viewed from above. If the refractive index of the glass is 1.5, what is the actual thickness of the glass block?

-
7. A stone at the bottom of a pool ($n = 1.33$) in a creek appears to be 2.1m from the surface. What is the true depth of the pool?

-
8. A liquid is 23cm deep with a refractive index of 1.26.
- a) What is its apparent depth when viewed from above?
- b) What is the critical angle for the liquid?

-
9. A student on a biology field trip dropped a coin in a creek ($n = 1.33$). The depth of the water appeared to be 75 cm so he rolled up his sleeves to retrieve the money.

- a) Calculate the real depth of the creek
- b) What would be a possible consequence of his action?



10. A boy stood 90 metres from the base of a rocky cliff and shouted to his friend who was standing at the base of the cliff. After 0.55 seconds the boy heard his own echo.

a) How far has the sound travelled?

b) What was the speed of sound?

11. A ship is floating at sea when the captain decides to confirm the depth by sending sound waves through sonar. It took the waves 0.05 seconds to reach the sea bed. He later confirmed that the depth is 70 metres when the sonar detected the reflected sound waves.

a) What is the echo time?

b) Calculate the speed of the sound waves in sea water.

Thank you for completing learning activity 5. Now check your work. Answers are at the end of the module.

NOW REVISE WELL USING THE MAIN POINTS ON THE NEXT PAGE.



SUMMARY

You will now revise this module before doing **ASSESSMENT 3**.

Here are the main points to help you revise. Refer to the module topics if you need more information.

- Wave motions only transfer energy and not the particles of the medium (water). The matter particles only vibrate but go back to their equilibrium position.
- Wave motions only transfers energy and not the matter (rope or spring) particles. The matter particles only vibrate but go back to their equilibrium position.
- Wave motions can be described in relations to the:
 - (i) Motion of the wave's energy and
 - (ii) Motions of the individual molecules (particles) of the wave
- A transverse wave is a wave that travels in the direction perpendicular to the direction of vibration or oscillation.
- A longitudinal wave is a wave that travels in the direction parallel to the direction of vibration or oscillation.
- A wave that requires a medium to propagate is called a mechanical wave.
- A wave that travels in a vacuum or empty space without a medium is called an electromagnetic wave.
- A crest is a point on the wave where the displacement of the medium is at a maximum
- A trough is a point on the wave where the displacement of the medium is at its minimum.
- Amplitude (A) is the maximum displacement from the rest or equilibrium position. It is the height of a crest or depth of a trough measured from the rest position. The higher the amplitude, the more energy the wave possesses.
- The period (T) of a wave is the time (in seconds) taken by the wave to move one wavelength or the time taken to produce one complete wave.

$$T = \frac{1}{f}$$

- The frequency (f) of a wave is the number of wavelengths per second. It is the number of complete waves produced in one second. The SI unit for frequency is hertz (Hz).

$$f = \frac{1}{T}$$

- A compression is a region in a longitudinal wave where the particles are closer together.
- A rarefaction is a region in a longitudinal wave where the particles are further apart.
- Wavelength (λ) is the distance between any two points in a wave which are in phase.
 - (i) For a transverse wave, it is the distance between two successive crests or troughs.
 - (ii) For a longitudinal wave, it is the distance between two successive compressions or rarefactions.
- Wave speed (v) is how fast a wave is moving and it depends on the medium. In a time of one period (T), a point on a wave moves a distance of one wavelength (λ).
- All waves obey the wave equation: $v = f\lambda$



- The principle of superposition states that the effect of the pulses is the sum of their individual effects.
- Any two points on a wave are said to be in phase when they move in the same direction, have the same speed and the same displacement from the rest or equilibrium position at the same time. Any two crests or troughs are always in phase.
- Points that are not in phase are said to be out of phase. These points are not separated by a complete number of wavelengths.
- Constructive interference is when two pulses meet, resulting in a bigger.
- Destructive interference is when two pulses meet, resulting in a smaller wave pulse.
- When waves travel from one medium to another, they can be reflected, refracted or diffracted.
- Reflection is the change in direction of propagation of a wave that strikes the boundary of different mediums. Reflection can be regular or diffused.
- The law of reflection that governs the reflection of light states that when a light ray reflects off a surface:
 - (i) The angle of incidence is equal to the angle of reflection.
 - (ii) The incident ray, the reflected ray and the normal all lie in the same plane.
- Refraction is the change in direction of a wave passing from one medium to another caused by its change in speed.
- The speed of light in a substance depends on the optical density or refractive index of the substance.
- Light passing into an optically denser medium is bent towards the normal; light passing into an optically less dense medium is bent away from the normal.
- The laws of refraction state that:
 - (i) The incident and refracted rays are on opposite sides of the normal at the point of incidence, and all three lie in the same plane.
 - (ii) The value of $\frac{\sin i}{\sin r}$ is a constant for light passing from one given medium into another. This is known as Snell's law.
- Snell's law states that for any two medium 1 and 2, the ratio of n_1 and n_2 is equal to the ratio of $\sin r$ and $\sin i$.
$$\frac{n_1}{n_2} = \frac{\sin r}{\sin i} \rightarrow n_1 \sin i = n_2 \sin r$$
- Refractive index of a medium gives you an indication of its light-bending ability.
$$\text{refractive index}(n) = \frac{\sin i}{\sin r}$$
- Greater the refractive index of a medium, the lower is the speed of light. The more light is slowed, the more it is bent.
- The relationship between refractive index and the speed of light is given by:



$$\text{refractive index} = \frac{\text{speed of light in vacuum}}{\text{speed of light in medium}}$$

$$n = \frac{c}{v}$$

$$\text{relative refractive index} = \frac{n_2}{n_1}$$

- Refraction of water waves is influenced by the depth of water. Water waves travel more slowly in shallow water than in deep water.
- Diffraction is the bending of waves as they pass through an opening (gap) or around the edge of an object in their path.
- Less diffraction occurs if the wavelength is smaller when they pass around an obstacle.
- Less diffraction occurs if the wavelength is smaller when they go through a larger gap (or opening)
- If an object is in the path of the travelling waves, a shadow is produced if the object is of the same size as the wavelength.
- Narrow gap and short wavelength produces large diffraction effect.
- Narrow gap and long wavelength produces large diffraction effect.
- Wide gap and long wavelength produces small diffraction effect.
- For total internal reflection to occur, light must travel from a substance of high optical density a substance of low optical density. It must strike at an angle greater than the critical angle of incidence.

$$\sin c = \frac{n_2 \sin 90^\circ}{n_1}$$

- The real depth and apparent depth are related to refractive index by the following equation:

$$\text{refractive index} = \frac{\text{real depth}}{\text{apparent depth}}$$

- Ultrasound is used naturally by animals like bats or whales to detect food and to navigate. It is used in industries to test for metal flaws and cleaning delicate machines. In medicine it is used in a number of ways which include the analysis of the development of unborn babies. In the maritime industry, ships use ultra sound to detect fish and measure seabed.

We hope you have enjoyed studying this module. We encourage you to revise well and complete Assessment 3.

**NOW YOU MUST COMPLETE ASSESSMENT TASK 3 AND
RETURN IT TO THE PROVINCIAL CENTRE CO-ORDINATOR**



Answers to Learning Activities 1 - 5

Learning Activity 1

1. Wave
2. Transverse wave
3. Longitudinal wave
4.
 - a) Motion of the wave's energy.
 - b) Motion of the individual molecules (particles) of the wave
5. Any of the following:
Vibration of string, the surface wave produced on the surface of solid and liquid (water), sound waves, tsunami waves, earthquake P-waves, ultra sounds, vibrations in gas, and oscillations in spring, internal water waves, and waves in a slinky spring coil.
6. Transverse waves are waves which travel in a direction perpendicular to the direction of vibration while longitudinal waves are waves which travel in the direction parallel to the direction of vibration.
7. The particles only vibrate but return to their original positions.
8. Compression
9. Rarefaction
10. Longitudinal

**Learning Activity 2**

1. a)

A. Crest

B. Wavelength

C. Crest

D. Amplitude

E. Amplitude

F. Trough

b)

W. Rarefaction

X. wavelength

Y. wavelength

Z. compression

2. 1.29m

$$\lambda = \frac{v}{f}$$

$$\lambda = \frac{330}{256}$$

$$\lambda = 1.29\text{m}$$

3. 0.66m

$$\lambda = \frac{v}{f}$$

$$\lambda = \frac{340}{512}$$

$$\lambda = 0.66\text{m}$$

4. $7.5 \times 10^{14}\text{Hz}$

$$f = \frac{v}{\lambda}$$

$$f = \frac{3.0 \times 10^8}{4 \times 10^{-7}}$$

$$f = 7.5 \times 10^{14}\text{ Hz}$$



5. a) 30cm = 0.3m from the graph (displacement)
b) 40cm = 0.4m from the graph
c) 2 Hz

$$f = \frac{1}{T}$$

$$f = \frac{1}{0.2}$$

$$f = 2\text{Hz}$$

- d) 0.08 m/s

$$v = f\lambda$$

$$v = 2 \times 0.04$$

$$v = 0.08\text{ms}^{-1}$$

2.

Colour	Frequency (Hz)	Wavelength (nm)
Red	$f = \frac{v}{\lambda} = \frac{3.0 \times 10^8}{7.5 \times 10^{-7}} = 4.3 \times 10^{14}\text{Hz}$	750 $7.5 \times 10^{-7}\text{m}$
Orange	$f = \frac{v}{\lambda} = \frac{3.0 \times 10^8}{6.0 \times 10^{-7}} = 5.0 \times 10^{14}\text{Hz}$	600 $6.0 \times 10^{-7}\text{m}$
Yellow	$f = \frac{v}{\lambda} = \frac{3.0 \times 10^8}{5.8 \times 10^{-7}} = 5.2 \times 10^{14}\text{Hz}$	580 $5.8 \times 10^{-7}\text{m}$
Green	$f = \frac{v}{\lambda} = \frac{3.0 \times 10^8}{7.5 \times 10^{-7}} = 4.3 \times 10^{14}\text{Hz}$	540 $5.4 \times 10^{-7}\text{m}$
Blue	$6.0 \times 10^{14}\text{Hz}$	$\lambda = \frac{v}{f} = \frac{3.0 \times 10^8}{6.0 \times 10^{14}} = 5.0 \times 10^{-7}\text{m}$ 500
Indigo	$6.7 \times 10^{14}\text{Hz}$	$\lambda = \frac{v}{f} = \frac{3.0 \times 10^8}{6.7 \times 10^{14}} = 4.5 \times 10^{-7}\text{m}$ 450

3. Period: $T = 0.8\text{s}$ from the graph
Frequency: $f = \frac{1}{T} = \frac{1}{0.8} = 1.25\text{Hz}$
Amplitude: $A = 1.0\text{m}$
Speed: $v = f\lambda = 1.25 \times 1.0 = 1.25\text{m/s}$

**Learning Activity 3**

1. The antinode
The antinode is continually vibrating from a high to a low displacement now that would be a ride.
 2. D
 3. C (8 nodes)
There are eight positions along the medium which have no displacement. Be sure to avoid the common mistake of not counting the end positions.
 4. B (7 antinodes)
There are seven positions along the medium which vibrate between a large positive and a large negative displacement. Be sure to avoid the common mistake of counting the antinodal positions twice. An antinode is simply a point along a medium which undergoes maximum displacement above and below the rest position. Do not count these positions twice.
 5. C (9 nodes)
There are nine positions along the medium which have no displacement. (Be sure to avoid the common mistake of not counting the end positions.)
 6. A
Destructive interference has occurred at points B, C and D to produce the nodes which are seen at these points.
-

Learning Activity 4

1. (i) The angle of incidence is equal to the angle of reflection.
(ii) The incident ray, the reflected ray and the normal, all lie in the same plane.
 2. The angle of incidence is 55° .
 3. (i) Diffuse (or irregular) reflection refers to reflection that has taken place on a rough surface.
(ii) Regular reflection refers to reflection that has taken place on a smooth shiny surface.
-

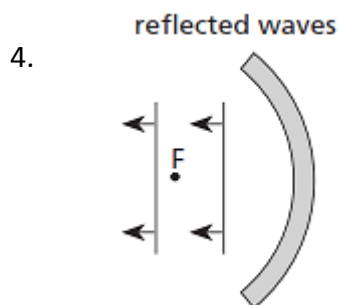

5.

$$n = \frac{c}{c}$$

$$= \frac{3 \times 10^8 \text{ ms}^{-1}}{2 \times 10^8 \text{ ms}^{-1}}$$

$$= 1.5$$

6.

$$c' = \frac{c}{n}$$

$$= \frac{3 \times 10^8 \text{ ms}^{-1}}{1.2}$$

$$= 2.5 \times 10^8 \text{ ms}^{-1}$$

7.

$$n_1 \sin i = n_2 \sin r$$

$$n_2 = \frac{n_1 \sin i}{\sin r}$$

$$= \frac{1.5 \times \sin 45^\circ}{\sin 65^\circ}$$

$$= 1.17$$

8. a)

$$c' = \frac{c}{n}$$

$$= \frac{3 \times 10^8 \text{ ms}^{-1}}{1.8}$$

$$= 1.67 \times 10^8 \text{ ms}^{-1}$$

b) The original angle of incidence is 20°

c) Find the angle of refraction and then take the difference.

$$\frac{\sin i}{\sin r} = n$$

$$\sin r = \frac{\sin i}{n}$$

$$\sin r = \frac{\sin 20^\circ}{1.80}$$

$$= 0.19001119$$

$$= \sin^{-1}(0.19001119)$$

$$= 11^\circ$$

Angle of deviation

$$20^\circ - 11^\circ = 9^\circ$$

- 9.
- a) $n_1 > n_2$
- b) $n_1 < n_2$
- c) $n_1 = n_2$

10. Find the frequency in the first region and then use the magnitude of the frequency with the speed in the second region to find the wavelength.

$$f = \frac{v}{\lambda} = \frac{7.5 \text{ cms}^{-1}}{3.5 \text{ cm}} = 2.1 \text{ Hz}$$

$$\lambda = \frac{v}{f} \quad \text{Therefore, } = \frac{5.5 \text{ cms}^{-1}}{2.1 \text{ Hz}} = 2.6 \text{ cm}$$

11. The resulting diffracted waves are as follows:

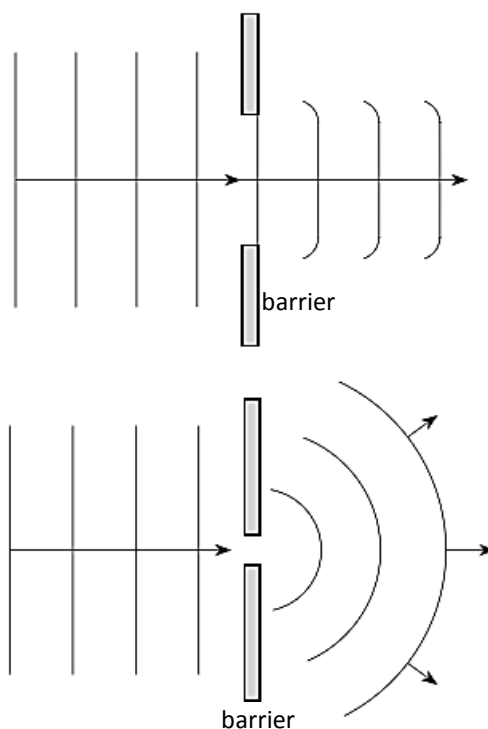

- 12.

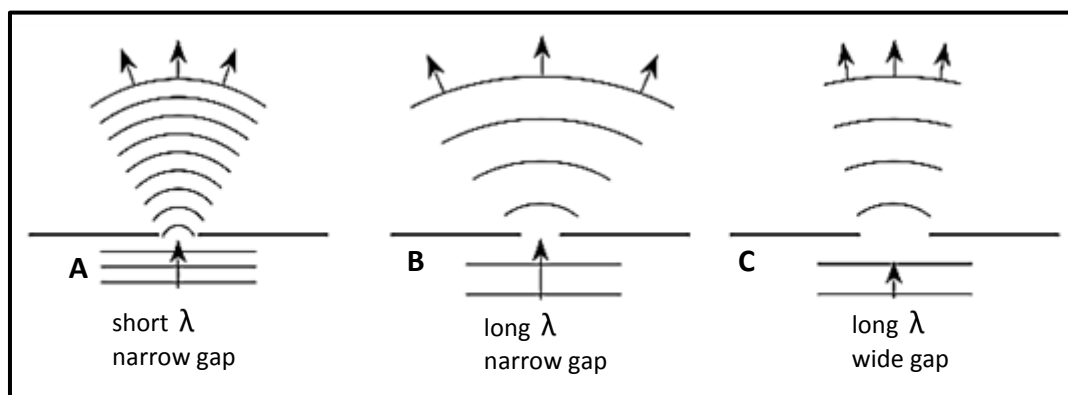

- A:** Narrow gap and short wavelength produces large diffraction effect.
B: Narrow gap and long wavelength produces large diffraction effect.
C: Wide gap and long wavelength produces small diffraction effect.

**Learning Activity 5**

1. Light must travel from a substance of high optical density into a substance of low optical density. It must strike at an angle greater than the critical angle of incidence.
2. They have an advantage over mirrors because mirrors produce multiple images as light is reflected from the back and front.
3.
 - a) ray A incident ray
 - b) $90^\circ - 50^\circ = 40^\circ$
ray B refracted ray
 - c) $n_1 \sin i = n_2 \sin r$
 $\sin r = \frac{n_1 \sin i}{n_2}$
 $= \frac{1 \times \sin 40^\circ}{1.49}$
 $= 0.431401$
 $= \sin^{-1}(0.431401)$
 $= 25.6^\circ$
 - d) $c' = \frac{c}{n}$
 $= \frac{3 \times 10^8 \text{ ms}^{-1}}{1.49}$
 $= 2.01 \times 10^8 \text{ ms}^{-1}$ or $201\,342\,282 \text{ ms}^{-1}$

If you have queries regarding the answers, then please visit your nearest FODE provincial centre and ask a distance tutor to assist you.



References

- Duncan, T & Kenneth, H (1986). GCSE Physics. 4th Ed. Hachette UK Company. UK.
- Harding, J & Lynch, D (2001) Oxford Physics Study Dictionary. Oxford University Press. Oxford.
- Kolkoma, D, Boereboom, J, Binns, A, Burchill, D, Housden, D & Kinsler, P (2012) Save Buk – 12 Physics – PNG Upper Secondary. Oxford University Press. Oxford
- Korimas, M & Soto, R (2005). A Text for First Year Physics At University of Papua New Guinea. Revised ed. University of Papua New Guinea, Port Moresby.
- Lucarelli, M (2004) Academic Associates – TEE Study Guide – Physics. 2nd Ed.
- Martine, R & Storen, A (2000). Nelson Physics – VCE Units 1&2. Updated 2nd Ed. Nelson Thomas Learning, Australia.
- Pople, S (1982). Explaining Physics, GCSE edition. Oxford University Press, Oxford, United Kingdom
- Pople, S (2001). Physics for Higher Tier. 3rd edition. Oxford University Press, Oxford, United Kingdom
- Walding, R, Rapkins, G & Rossiter, G (1999). New Century Senior Physics – Concepts in context. 2nd Ed. Oxford University Press, Oxford, UK.
- <http://www.videojug.com/film/how-to-calculate-wavelength>
- <http://www.physicsclassroom.com/Class/waves/u10l2e.cfm>